

CONCISE USER MANUAL



μ-FEP

FIRE DETECTION EXTINGUISHING CONTROL PANEL



TABLE OF CONTENTS

1	DOCUMENT REVISION DETAILS	3
2	IMPORTANT NOTE	3
3	WARRANTY	3
4	INTRODUCTION	4
5	ENCLOSURE & INSTALLATION	4
6	FEATURES	5
6.1	ACOUSTIC ALARM	5
6.2	EMERGENCY POWER	5
6.3	MONITORED INPUTS	5
6.4	DETECTION ZONES	5
6.5	EXTERNAL RELEASE INPUT	5
6.6	EXTINGUISHING DELAY	5
6.7	EXTERNAL HOLD INPUT	5
6.8	MONITORED OUTPUTS	5
7	μ-FEP CONTROL PANEL FASCIA	6
7.1	CONTROL BUTTONS	6
7.1.1	Mute	6
7.1.2	Reset	6
7.1.3	Lamp test	6
7.1.4	Hold extinguishing release	6
7.1.5	Test mode	6
7.1.6	Backup power off	6
7.1.7	Extinguishing release	6
7.2	LED INDICATORS	7
7.2.1	General fire alarm	7
7.2.2	Power	7
7.2.3	Backup power	7
7.2.4	Test mode	7
7.2.5	General fault	7
7.2.6	Fire zone alarm	7
7.2.7	Fire zone fault	7
7.2.8	Extinguishing released	7
7.2.9	Extinguishing delay	7
7.2.10	Extinguishing release hold	7
7.2.11	Extinguishing fault	7
7.2.12	Internal fault indicators	7
8	PROGRAMMING DIP SWITCHES	8
8.1	EXTINGUISHING DELAY TIMER	8
8.2	MUTE BUZZER	8
8.3	LATCHING/NON-LATCHING	8
8.4	SINGLE OR DUAL FIRE ALARM	8
8.5	DIRECT RELEASE	8
8.6	NO AUTOMATIC RELEASE	8
10	TECHNICAL SPECIFICATION	9
11	μ-FEP MAIN WIRING DIAGRAM	9
12	μ-FEP FIRE DETECTOR AND WIRING OPTIONS	10
13	μ-FEP EXTERNAL EXTINGUISHERS RELEASE & HOLD WIRING OPTIONS	11
14	μ-FEP EXTERNAL VTB SOUNDER & BEACON WIRING OPTIONS	11
15	μ-FEP FIRE EXTINGUISHERS WIRING OPTION	12
15.1	μ-ETB OPTION	12
15.2	ALTERNATIVE OPTION (NOT SECURED)	12

1 DOCUMENT REVISION DETAILS

Issue	Modification Detail	Author	Date
1	1 st publication document	CvT	01 / 01 / 2021
2	Text adaptation chapter 2 and 6.2	CvT	28 / 04 / 2022
3	Test mode improved	CvT	01 / 02 / 2025

2 IMPORTANT NOTE

This concise user manual provides you with basic installation and major operation instructions. A limited set of features are described. This concise user manual is an integral part of the extended and original μ -FEP user manual. This document should be thoroughly read and understood before installation and/or commissioning of the system is undertaken. The μ -FEP system is not to be regarded as properly used when it is used without regard to any relevant information or advice relating to its use that has been made available by the supplier. The μ -FEP system and the associated connections must be installed, commissioned, and maintained by a skilled, knowledgeable, and competent person or organization that is appropriately qualified to perform this work and is familiar with the objective of the equipment and the associated technical terminology. This equipment is not guaranteed unless the complete installation is installed and commissioned in accordance with the laid down local and/or national standards by an approved and competent person or organization. Other manuals associated with the μ -FEP system are the compatible devices, concise user, owners, Modbus and the test panel user manual.

3 WARRANTY

K&G Groep BV represents the μ -FEP system and is free from material defects in materials and workmanship. Our warranty does not cover a μ -FEP system which is damaged, misused, and/or used contrary to the supplied operating manuals or which has been repaired or altered by others. The liability of K&G Groep BV is at all times limited to repair or, at K&G Groep BV's discretion, replacement of the μ -FEP system. K&G Groep BV shall not under any circumstances be liable for any indirect, special or consequential damages such as, but not limited to, damage or loss of property or equipment, cost of de-installation or reinstallation, cost of transport or storage, loss of profits or revenue, cost of capital, cost of purchased or replacement goods, or any claims by customers of the original purchaser or third parties or any other similar loss or damage, whether incurred directly or indirectly. Remedies set forth herein to the original purchaser and all others shall not exceed the price of the μ -FEP system supplied. This warranty is exclusive and expressly in lieu of all other warranties, whether expressed or implied, including, without limitation, any warranties of merchantability or fitness for a particular purpose.

Reservations

The diagrams of operating principles of the μ -FEP fire detection and extinguishing system, included in this manual, are only intended to support this manual. No part of this manual may be reproduced, stored in an automated database, or made public in any form or by any means either electronically, mechanically or by photocopying, recording, or in any other way, without prior written permission from K&G Groep BV. The policy of the K&G Groep BV is one of continuous improvement, and as such, we reserve the right to make changes to product specifications at any time and without prior notice. Errors and omissions excepted.



4 INTRODUCTION

The μ -FEP is designed as a stand-alone fire detection and extinguishant release panel to be used in systems for e.g., electrical cabinets, CNC machines, engine rooms, small areas, or with other equipment. The μ -FEP control panel is designed to meet the requirements of the European standard EN54-2 Fire Detection and Fire Alarm systems - Control and Indicating Equipment, EN12094-1 Fixed Firefighting Systems Part 1: requirements and test methods for electrical automatic control and NEN-EN 15276-2 Aerosol Fire Extinguishing Systems.

5 ENCLOSURE & INSTALLATION

The μ -FEP control panel should be mounted on a dry, flat surface, at eye height to the signaling and operating panel, in a horizontal position so that the enclosure cannot be deformed. The μ -FEP should be installed in an accessible

area. Suitable fixings should be used at all μ -FEP fixing points such that the panel is securely mounted and is not liable to move once fixed. Take into consideration environmental factors such as high temperatures and/or magnetic fields. To ensure IP rating the cables must be brought in using the provided cable glands.



the panel. Open the enclosure by means of a screwdriver (size 3).

The FEP housing consists of two parts, so it can easily be mounted by hand. The rear part with the terminal block in it and the front part with the panel electronics. The two parts are connected to each other by a flat cable. Before installing start with separating the rear part (backbox) from the front part of

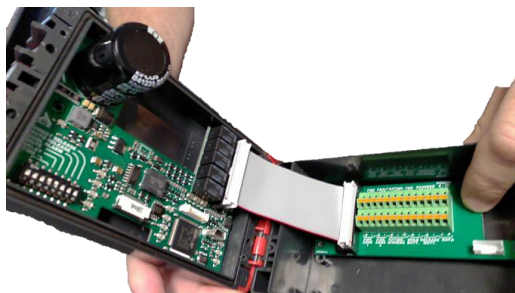

Mount the rear part (backbox) at the desired location. The hinged catch of this enclosure conceals the installation screws. Connect the required cables with sufficient length and connect them to the terminal block according to the connection requirements. After the cable glands have been tightened, the front part with the electronics must be re-installed and the flat cable must be re-connected.

6 FEATURES

6.1 ACOUSTIC ALARM

The μ -FEP has an internal attention signal. Malfunctions are standard signaled with a continuous tone signal, alarms with a pulsating tone signal.

6.2 EMERGENCY POWER

The μ -FEP is equipped with an emergency power supply of approximately 3,5 hours in the event of a main power failure. To reach the maximum time of emergency power, it is important that the power consumption during the emergency power status is as low as possible. Only the primary functions such as fire detection, extinguishing release and fault messages are maintained. The other VFC relays are disabled. The main objective of μ -FEP's emergency power supply is to be able to permanently detect and extinguish a fire using its own emergency power supply in the event of a complete power failure. Replacing the LIR2477 battery every 3 years will prevent shortening the standby time and prevent power down in case of increased power consumption during alarm state.

6.3 MONITORED INPUTS

The μ -FEP is equipped with two detection zones and two external button inputs (Extinguishing Release & Hold). These inputs are continuously scanned for alarm or fault detection.

6.4 DETECTION ZONES

The μ -FEP is equipped with two detection zone inputs. The loop inputs are continuously scanned for fire or fault detection.

6.5 EXTERNAL RELEASE INPUT

The external extinguishing input has the same function as the dual release extinguishing buttons (on the front of the panel). By pressing the external release extinguishing button, the fire extinguisher(s) will be released.

6.6 EXTINGUISHING DELAY

It is possible to delay the extinguishing release. The delayed can be set from 0 to 30 seconds in steps of 5 seconds.

6.7 EXTERNAL HOLD INPUT

The μ -FEP has a separate input for an external hold-off button. The external hold-off button has the same function as the internal hold-off button. When an alarm is active and this button is pressed, the extinguisher release is delayed. When the button is released, the system will wait the configured time delay. Release of the Hold input shall re-start the countdown release timer from maximum.

6.8 MONITORED OUTPUTS

The μ -FEP is equipped with six outputs, two monitored and four potential free. The monitored outputs intended for the extinguishers and the sounders/beacons are continuously scanned for open and short circuit fault conditions. The four potential free outputs have a contact load of 30 VDC /1A.

7 μ -FEP CONTROL PANEL FASCIA

The μ -FEP has a clear and orderly front panel with which the system status of the μ -FEP can be determined rapidly. The figure shows the controls and LED indicators.

7.1 CONTROL BUTTONS

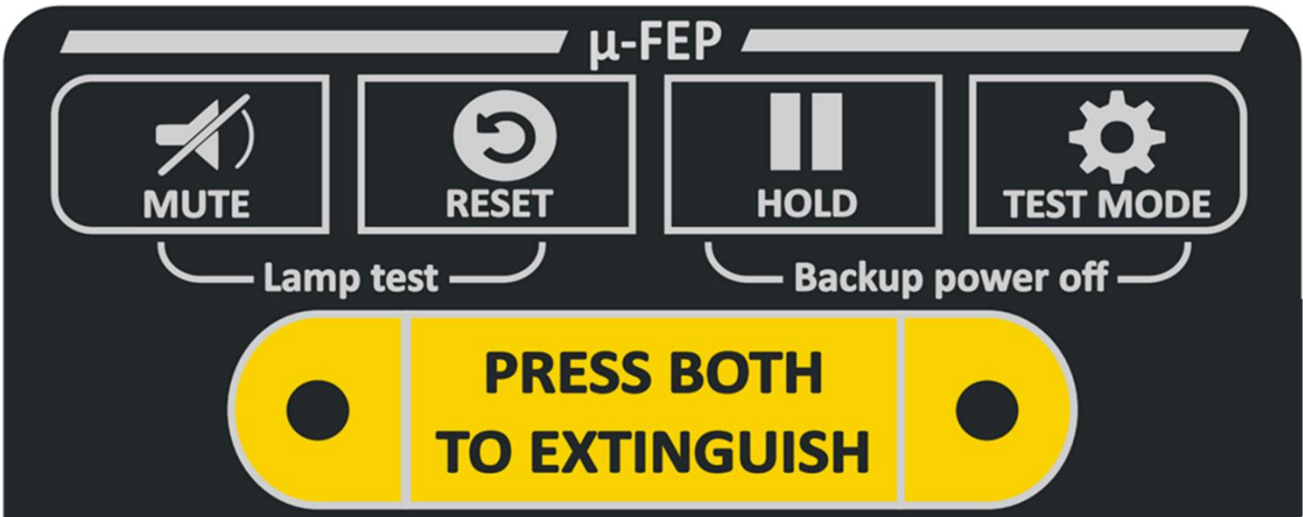

7.1.1 Mute

The buzzer can be silenced at any time by pressing the Mute button. To silence the external sounder, press twice.

7.1.2 Reset

After the cause of the alarm has been determined the μ -FEP can be reset by pressing the Reset button. Manual Call Points, if triggered, must first be reset locally.

7.1.3 Lamp test

All indicators and buzzer can be test at any time by pressing the **Mute and Reset** simultaneously.

7.1.4 Hold extinguishing release

By pressing the hold button on the panel or external hold button will, as long this button is pressed, the extinguishing release sequence will be halted and the yellow hold indicator flash. Release the Hold button shall re-start the countdown release sequence from start.

7.1.5 Test mode

In test mode you can check the alarm and fault circuits without activating the extinguishers. Press the test mode button for 3 seconds to enable the test mode. Press test mode button again for 3 seconds to bring the system back to normal status.

7.1.6 Backup power off

By pressing the **Hold and Test** button simultaneously the emergency power supply is turned off. In the case of service, wiring or maintenance work, it is important that not only the main power, but also the emergency power is turned off.

7.1.7 Extinguishing release

When a fire emerges, press both front extinguishing release buttons, this will trigger an alarm, and the fire extinguishers will be released, depending on the dip switch (time) settings.

7.2 LED INDICATORS

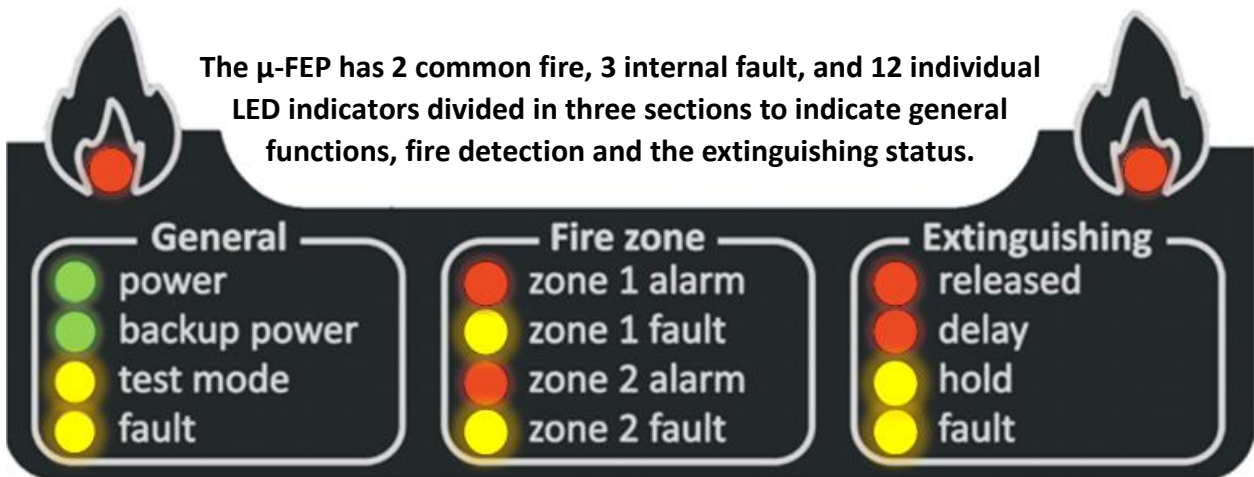

7.2.1 General fire alarm

Two red indicators illuminated when any zone is activated or by pressing the internal or external extinguishing release button.

7.2.2 Power

The green power indicator is normally illuminated to indicate the system is operating correctly.

7.2.3 Backup power

This green LED indicates the emergency power status of the μ -FEP.

7.2.4 Test mode

The yellow test LED indicator lights continuously indicating the system is in test mode.

7.2.5 General fault

This yellow LED which flashes when any fault is detected on the system.

7.2.6 Fire zone alarm

Two red LEDs associated with each zone which flash when the relevant zone is activated

7.2.7 Fire zone fault

Two yellow LEDs associated with each zone which illuminates when a fault is detected

7.2.8 Extinguishing released

A red LED which indicates that the extinguishant has been released.

7.2.9 Extinguishing delay

A red LED which indicates the discharge sequence is in progress and released when time delay expires.

7.2.10 Extinguishing release hold

A yellow LED which indicates that the associated extinguishing Hold button is pressed.

7.2.11 Extinguishing fault

This yellow LED illuminate when any fault is detected in the extinguishing output line.

7.2.12 Internal fault indicators

Three yellow fault LEDs for 2nd priority fault messages in the external extinguishing hold and extinguishing release input and a fault in the monitored sounder/beacon line.



8 PROGRAMMING DIP SWITCHES

The common setting of a μ -FEP system is based on installers/supplier experience. Under normal circumstances only the green power LED illuminated to indicate the system is operating correctly.

Setting when all dip switches are in off position is:

- The extinguishing delay time is 0
- The internal buzzer is not muted
- The fire detection zones operate in the latching mode
- Dual zone alarm for automatic extinguishing release
- A manual activated extinguishing release is also delayed
- The extinguishing system is in automatic/manual activation mode

8.1 EXTINGUISHING DELAY TIMER

For the delay timer settings, there are 3 dipswitches. This timer can be set with the use of the dipswitches 1,2 and 3. The timer is changeable between 0 and 30 seconds, with steps of 5 seconds.

8.2 MUTE BUZZER

The acoustic attention signal of the μ -FEP is activated with every action or reaction on the panel. The acoustic signal can be temporarily switched off with the dip switch 4.

8.3 LATCHING/NON-LATCHING

Normally the automatic detection zone is latching. A fire alarm will remain on the panel until the panel has been reset. That is the latching status. In the non-latching status, the fire alarm zone is self-resetting and will reset the alarm. Non-latching feature is NOT applicable at any type of detector.

8.4 SINGLE OR DUAL FIRE ALARM

The discharge sequence is initiated by the activation of fire detectors in zones 1 and 2. If single mode is programmed than the discharge sequence is activated by either zone 1 or 2.

8.5 DIRECT RELEASE

Direct extinguish dipswitch override the release delay. Manual release operated at any time without any delay.

8.6 NO AUTOMATIC RELEASE

Only Manual release operated at any time without any delay. In the Manual mode the activation of one or more fire detectors on zones 1 and 2 causes a first stage alarm and trigger the fire alarm leds and relay output

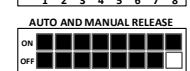
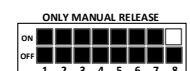
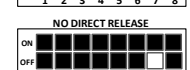
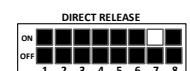
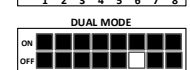
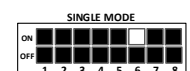
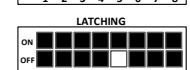
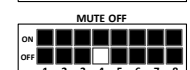
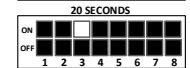
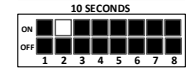
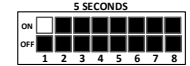
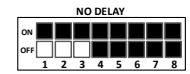
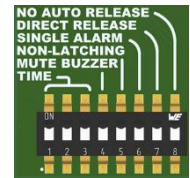

9 CONNECTION & CABLE AND WIRING SPECIFICATIONS

Wiring & cable specifications:

- Use a twisted cable, this strength the protection against electrical or magnetic field influences.
- Minimal solid copper core diameter, extinguisher line 1,0mm² (AWG 17)
- Minimal solid copper core diameter, other cables 0,5mm² (AWG 20)
- Maximum solid copper core diameter other cables 1,5mm² (AWG 16)
- Maximum wire resistance 3,5 Ω.
- Maximum cable length of the fire zone and the extinguisher cables is 100 meters
- Maximum cable length other cables maximum 30 meter
- General fire, fault, extinguishing release, and ventilation relay are normally open contacts
- Sounder beacon -1 is stage one and -2 is stage two alarm

10 TECHNICAL SPECIFICATION

For more and detailed technical specifications, refer to our standard and extensive user manual.

Ambient Temperature Range	-10 to 50 degrees Celsius
Dust and water rating	IP66
Input voltage	6 to 28 VDC
Maximum power usage	5 Watt
Maximum voltage VFC	30 VDC
Maximum current VFC	1 A

11 μ-FEP MAIN WIRING DIAGRAM

The diagram below shows the μ-FEP connections options

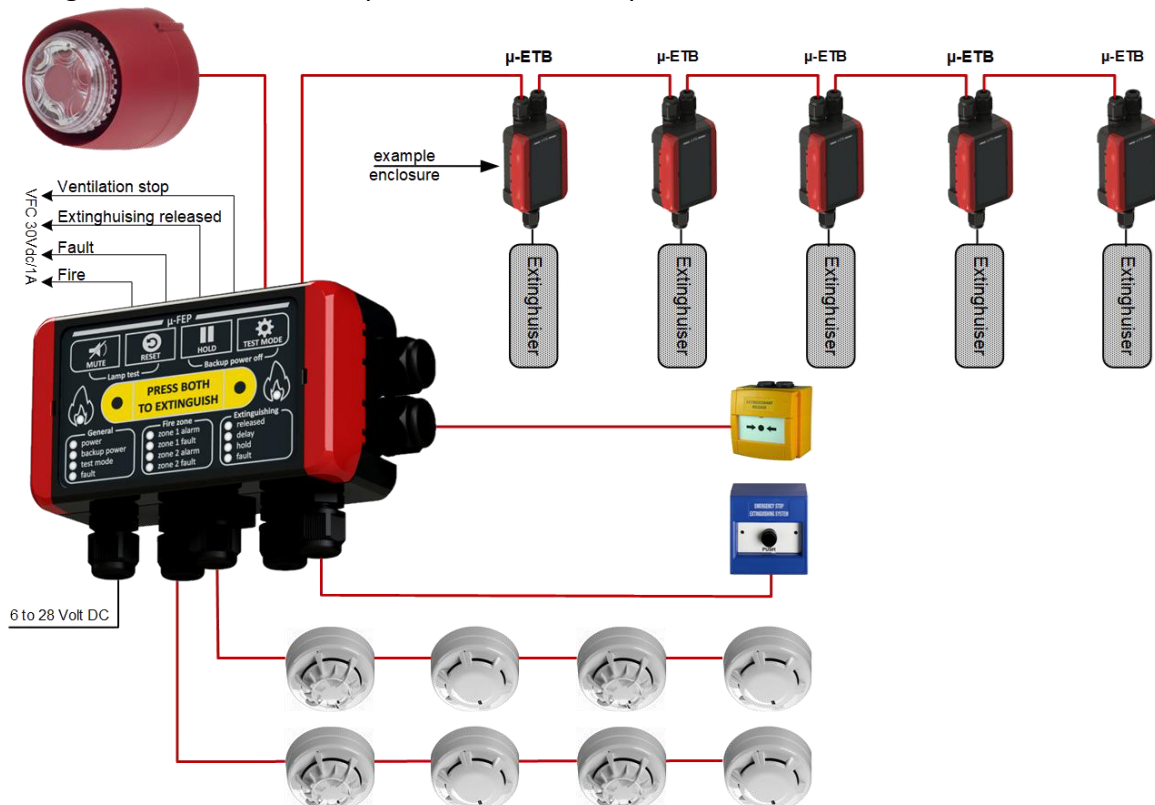

12 μ -FEP FIRE DETECTOR AND WIRING OPTIONS

There are three options for connecting fire detectors to the μ -FEP.

- Conventional Apollo Orbis fire detectors
- Fenwal heat detectors
- Linear cable heat detection

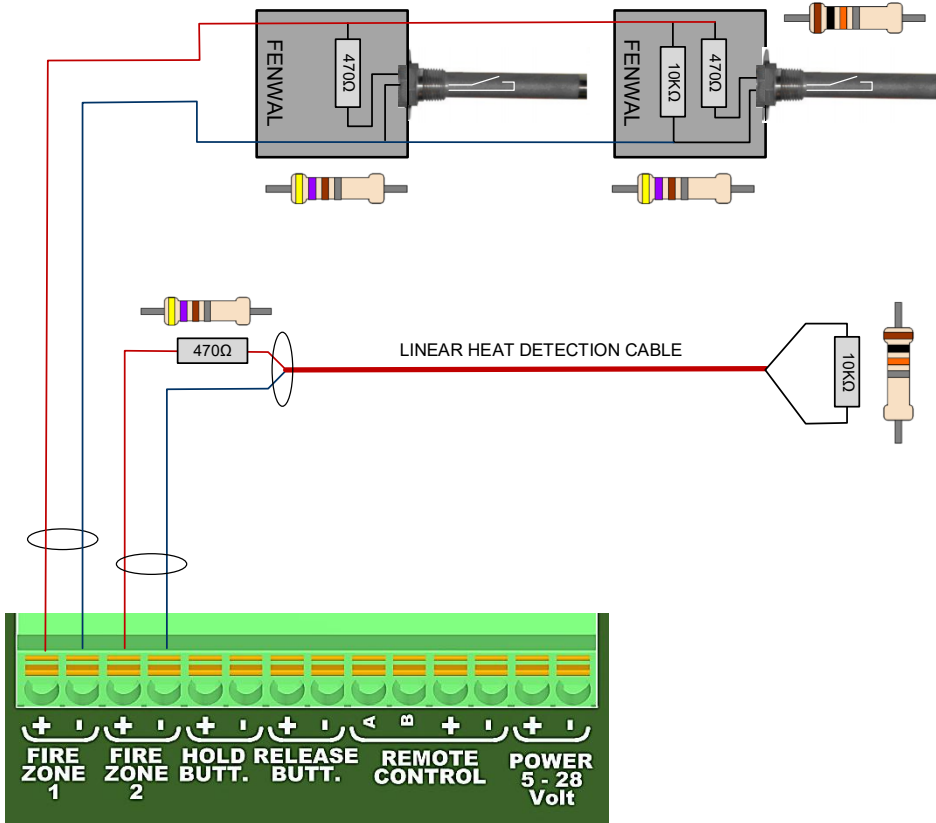
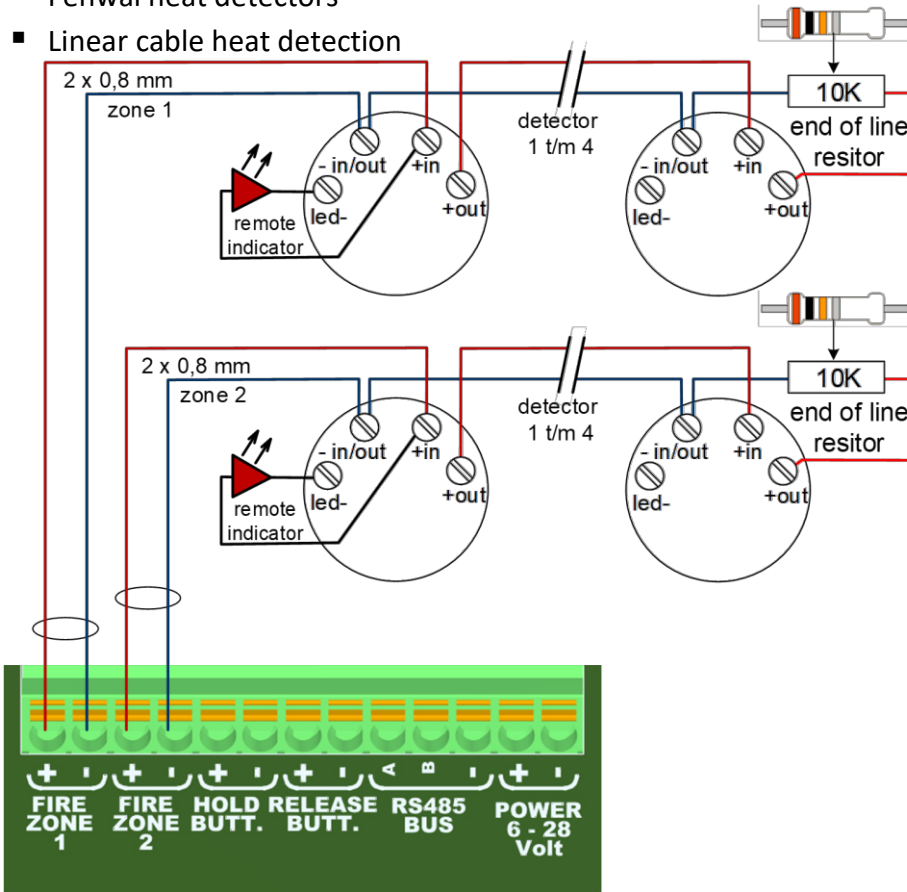

13 μ-FEP EXTERNAL EXTINGUISHERS RELEASE & HOLD WIRING OPTIONS

The μ-FEP has a separate input for external extinguishing release and external hold-off button.

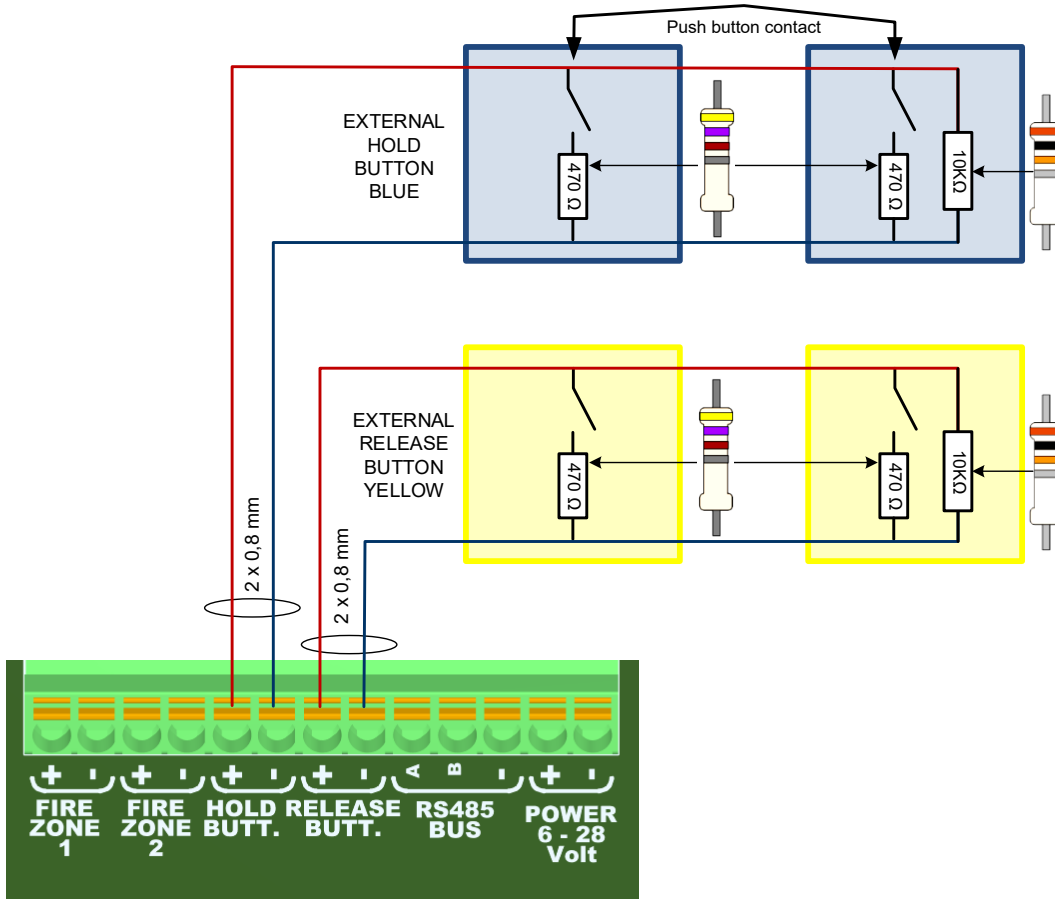

14 μ-FEP EXTERNAL VTB SOUNDER & BEACON WIRING OPTIONS

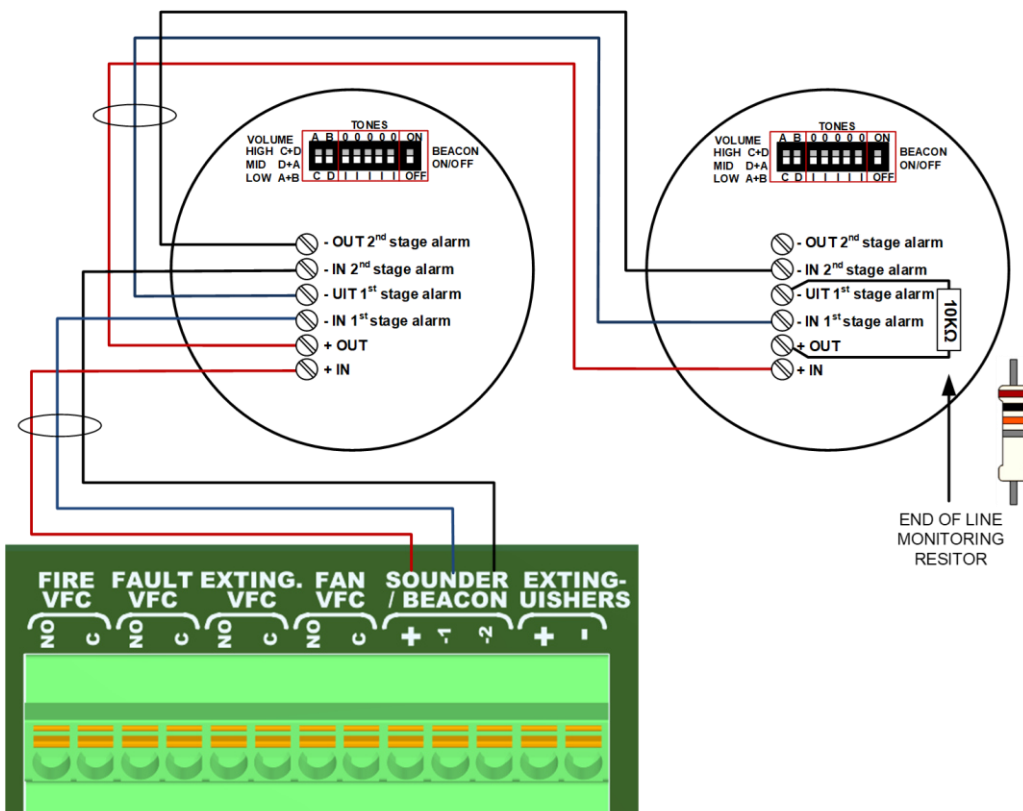

15 μ -FEP FIRE EXTINGUISHERS WIRING OPTION

There are two ways to connect the aerosol generator to the system.
 With the μ -ETB terminal board or with an IP-protected junction box

15.1 μ -ETB OPTION

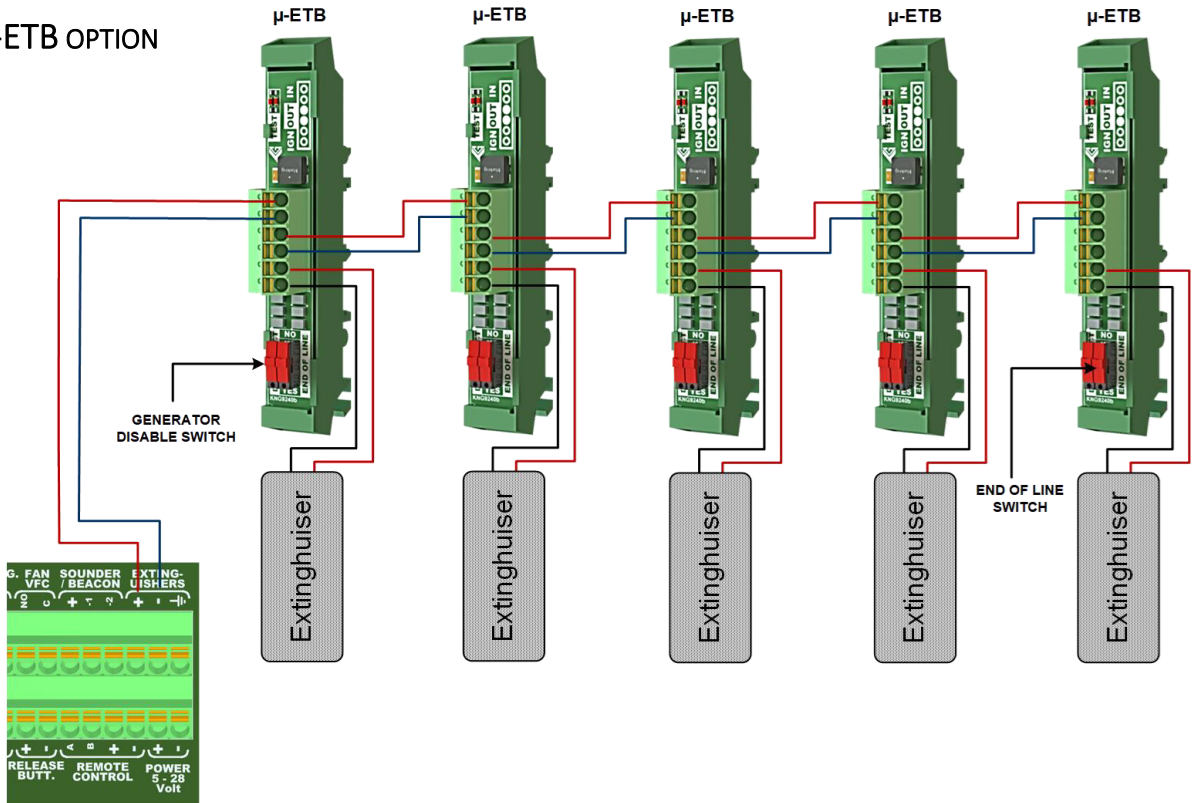

15.2 ALTERNATIVE OPTION (NOT SECURED)

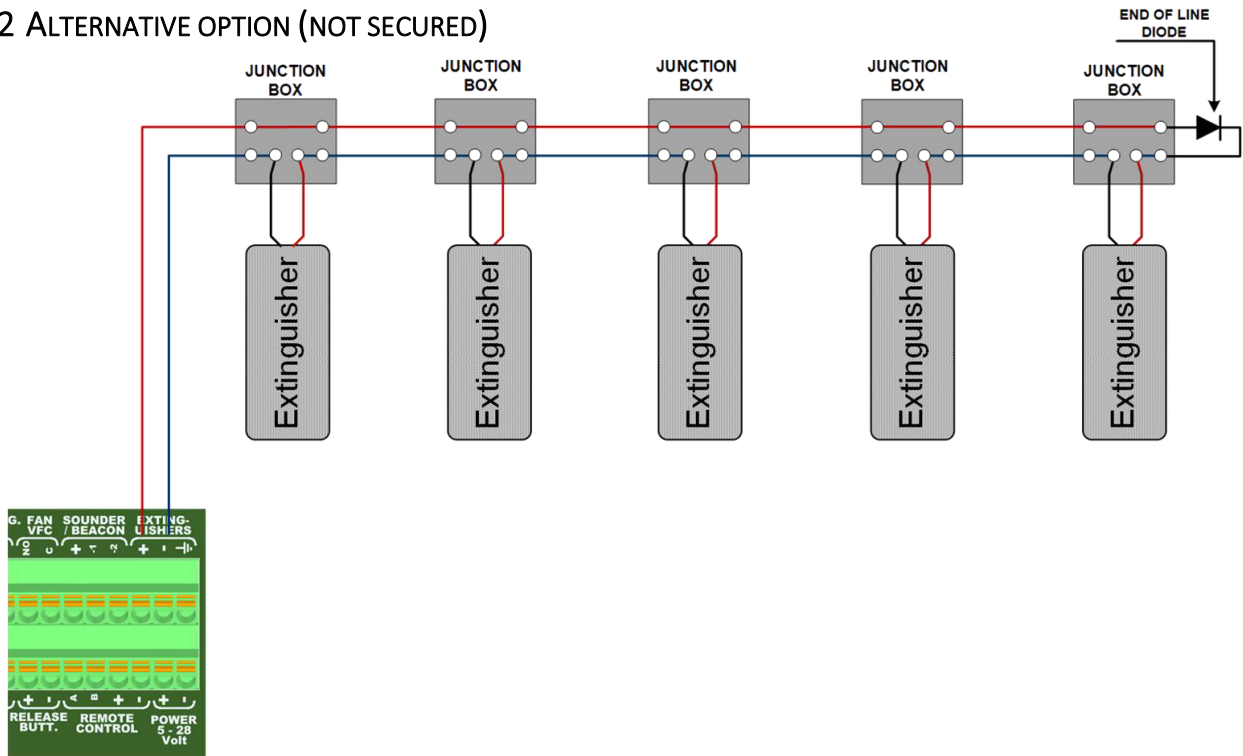

Outdated or replaced computers and electronics are valuable sources for secondary raw materials if recycled. Dealers of the μ -FEP system must comply with local regulations for waste separation applicable in the country where the supplier is located. Questions concerning the information presented in this manual may be addressed to your dealer. For technical questions or support contact your dealer for further assistance.

