

Owner's Manual



NANO

FIRE DETECTION & EXTINGUISHING CONTROL SYSTEM



TABLE OF CONTENTS

1	FOREWORD	3
2	INTRODUCTION	3
3	WARRANTY	3
4	MAINTENANCE & CLEANING	4
5	KEY PROPERTIES	4
6	FEATURES NANO	5
	6.1 ACOUSTIC ALARM	5
	6.2 EXTINGUISHANT RELEASE OUTPUT	5
	6.3 HISTORIC EVENT LOG	5
	6.4 COMMUNICATION PORT	5
	6.5 DIRECT RELEASE	5
	6.6 VEHICLE MODE	5
	6.7 GENERAL FAULT RELAY	5
	6.8 VFC FIRE RELAY ACTIVE IN SINGLE OF DUAL MODE ALARM	5
	6.9 SINGLE OR DUAL ZONE	5
	6.10 EXTINGUISHANT RELEASE DELAY	5
7	NANO CONTROL PANEL FACIA	6
8	CONTROL BUTTONS	6
	8.1 MUTE	6
	8.2 RESET	6
	8.3 LAMP TEST	6
	8.4 HOLD EXTINGUISHING RELEASE	6
	8.5 AUTOMATIC & MANUAL RELEASE OR MANUAL ONLY MODE	6
	8.6 EXTINGUISHING RELEASE	6
9	LED INDICATORS	7
	9.1 MANUAL RELEASE ONLY	7
	9.2 AUTOMATIC & MANUAL RELEASE	7
	9.3 POWER	7
	9.4 COMMON FIRE	7
	9.5 FIRE ZONE ALARM	7
	9.6 EXTINGUISHING RELEASED	8
	9.7 EXTINGUISHING DELAYED	8
	9.8 GENERAL FAULT	8
	9.9 FIRE ZONE FAULT	8
	9.10 EXTINGUISHING RELEASE HOLD	8
	9.11 EXTINGUISHING RELEASE FAULT	8
	9.12 INTERNAL FAULT INDICATORS	8
10	COMMON SETTINGS	9
11	WHAT TO DO RECOMMENDATIONS	9
	11.1 WHAT TO DO IN THE EVENT OF A FIRE ALARM CONDITION	9
	11.2 WHAT TO DO IN THE EVENT OF A FAULT CONDITION	9
	11.3 ROUTINE TESTING RECOMMENDATIONS	9
	11.4 WARNING	9
12	MAINTENANCE RECOMMENDATIONS	10
	12.1 TEST THE NANO SYSTEM WITHOUT ACTIVATING THE EXTINGUISHERS.	10
	12.2 TEST THE NANO SYSTEM WITHOUT ACTIVATING THE EXTINGUISHERS	10
	12.3 DAILY TESTING (PREMISES MANAGEMENT)	11
	12.4 WEEKLY TESTING (PREMISES MANAGEMENT)	11
	12.5 QUARTERLY TESTING (COMPETENT PERSON)	11
	12.6 YEARLY TESTING (COMPETENT PERSON)	11
13	NOTES	12



1 FOREWORD

This owner's manual must be thoroughly read and understood before using and operating the NANO system and is intended for end users. The NANO system and the associated connections must be installed, commissioned, and maintained by a skilled, knowledgeable, and competent person or organization that is appropriately qualified to perform this work and is familiar with the objective of the equipment and the associated technical terminology. The NANO has successfully passed CE and FCC, EMC testing according to EN 50130, EN 61000, EN 55016, 47 CFR15-ICES-003, ANSI 63.4 and a DNV-CG type approval according to the Class Guideline 0339. For that the NANO has endured extensive environmental tests such as vibration, dry heat, damp heat and cold tests in accordance with the requirements of the DNV-CG 0339 standard.

2 INTRODUCTION

The NANO is designed to be a stand-alone fire detection-/extinguishing release panel used in systems for extinguishing engine rooms, small areas, or other equipment in vessels in which the user should be able to extinguish a fire rapidly and effectively. This is done by simultaneously pressing the two push buttons either on the front of the NANO panel or on the door of the ETB/BOX. The NANO system monitored continuously its in and outputs and, in the event of a fire, provides the appropriate information to justify a decision to extinguish. In a marine application, it is NOT common for a fire suppression system intended for an engine room to be released by an automatic fire detector. But the NANO can also operate as a combined fire alarm control and extinguishant release system, it has two detection zones, any, or all of which can contribute to the extinguishant release decision.

3 WARRANTY

N2KB BV represents the NANO system and is free from material defects in materials and workmanship. Our warranty does not cover a NANO system which is damaged, misused, and/or used contrary to the supplied operating manuals or which has been repaired or altered by others. The liability of N2KB BV is at all times limited to repair or, at N2KB BV's discretion, replacement of the NANO system. N2KB BV shall not under any circumstances be liable for any indirect, special, or consequential damages such as, but not limited to, damage or loss of property or equipment, cost of de-installation or reinstallation, cost of transport or storage, loss of profits or revenue, cost of capital, cost of purchased or replacement goods, or any claims by customers of the original purchaser or third parties or any other similar loss or damage, whether incurred directly or indirectly. Remedies set forth herein to the original purchaser and all others shall not exceed the price of the NANO system supplied. This warranty is exclusive and expressly in lieu of all other warranties, whether expressed or implied, including, without limitation, any warranties of merchantability or fitness for a particular purpose.

It is the responsibility of the premises management to define the fire procedures and ensure that all relevant users are trained and that fire drills are performed with appropriate isolation measures in place to ensure that accidental discharge of the extinguishant agent is avoided. It is also the responsibility of the premises management to ensure that there is nothing that can impede the operation of the fire detection and extinguishant system and prevent any obstructions from blocking fire detection/activation devices.

This owner's manual only applies to the NANO detection and activation system.

For more information about the management, inspection, and maintenance procedures of the extinguishing system, please contact your extinguishing system supplier.



4 MAINTENANCE & CLEANING

There are not user-replaceable parts in the NANO. Take Electrostatic Discharge (ESD) precautions when opening the NANO. Always wear a properly grounded anti-static wrist strap. Avoid direct contact with any of the components or connectors connected to the printed circuit board. Never let the electronics come in contact with clothing. The ground strap cannot dissipate static charges from fabrics. Failure to follow accepted ESD handling practices could cause damage to the NANO. It is important to note that improper cleaning of the NANO front can damage this panel inhibit their ability to sense fire and activate the fire extinguishers. To remove dust and contaminants, **use nonalcoholic** products which has been designed for that purpose.

Do not use high pressure or stream cleaners.

5 KEY PROPERTIES

The NANO is not only developed for land based installations, but can also applied in marine applications. It has a DNV-CG Type Approval in accordance the 0339 standard. The NANO solution consists of two components. The basis is formed by the NANO control panel which is placed on the bridge or in its vicinity. Then there is an extinguisher terminal box (ETB). This ETB box must be placed outside, but in the immediate vicinity of the to protected engine room. ETB/L is suitable for igniters with a resistance of max 2Ω. The ETB/H is suitable for igniters with a resistance of max 4Ω. The fire extinguishers will be released, depending on the DIP switch (time) settings. In a marine application, it is NOT common for a fire suppression system intended for an engine room to be released by an automatic fire detector. But the NANO has two fire zones suitable for connecting Apollo Orbis Marine approved fire detectors. The NANO system can be set up so that fire alarms from these Apollo fire detectors are detected, signaled, and reported on the NANO control panel, but considered than as informative/exploratory only. By default, the NANO is set to only manual release, but can be changed to automatic & manual mode.

- Able to set to manual, single stage or double stage detection, alarm, and extinguishing
- Outputs for fire, fault, extinguishing released, ventilation off and visual & acoustic alarm device
- A full monitored output for the aerosol fire extinguishing generators
- Two full monitored fire alarm input groups (zones) for linear heat and / or point detectors
- Two full monitored alarm input groups for external extinguishing release and hold function
- Double extinguisher release buttons to prevent unwanted releases
- Extinguishers hold release button to postpone releases
- Extinguisher release delay to prevent unwanted releases
- Extinguishing delay which can be set between 0 and 35 seconds
- Additional option to override the release extinguishing delay after manual release
- Additional functionality regarding separated external hold-off functions
- Additional functionality regarding separated external release extinguishing functions
- Historic event log memory readable from a mini-USB port
- Modbus RS485 communication port
- The NANO works on input voltage 8 to 28 Volt DC
- The NANO has an IP 65 waterproof enclosure, with cable glands
- ESD and EMC protected, and CE and FCC marked.
- DNV-CG type approval; according the 0339 DNV-CG Class Guideline Standard 0339



6 FEATURES NANO

6.1 ACOUSTIC ALARM

The NANO has an internal attention signal and a monitored output for external sounder/beacon.

6.2 EXTINGUISHANT RELEASE OUTPUT

The N2KB NANO is equipped with two activation techniques for the activation of a fire extinguishing system. By default, the NANO is programmed for the activation of electrical igniters intended for aerosol fire extinguisher generators or activating an extinguishing system with a solenoid.

6.3 HISTORIC EVENT LOG

The NANO has an historic event log memory of 10.000 events readable from a USB port. Connect an USB cable between the Mini-B USB port and your computer. The device will function as an USB stick.

6.4 COMMUNICATION PORT

The NANO has a Modbus network connection. Modbus enables communication among devices connected to the same network.

6.5 DIRECT RELEASE

When the timer settings are set to a delay (between 10 – 35 seconds), the direct extinguish DIP switch gives the choose to override the delay in case of a fire event. This function can be selected via DP1.

6.6 VEHICLE MODE

If the extinguishing system is intended for the protection of a vehicle engine bay, then a programmed extinguishing delay must be disabled, when the vehicle is parked, and the driver leaves the vehicle. Please note that the vehicle mode does not work in the only manual mode.

6.7 GENERAL FAULT RELAY

The general fault relay signalizes, any fault in the NANO. The general fault relay is energized in quiescent state. In the event of a complete power failure, the general fault relay becomes inactive.

6.8 VFC FIRE RELAY ACTIVE IN SINGLE OF DUAL MODE ALARM

A single or dual FIRE indication can trigger the VFC relay. You can choice to have the potential free contact active at the first or at the second fire alarm. This function can be selected via dip switch 5.

6.9 SINGLE OR DUAL ZONE

Usually, the extinguishing system is activated in the so-called two group-dependent status (avoiding coincidence). Two fire conditions must be met before an extinguishing activation will be initiated.

6.10 EXTINGUISHANT RELEASE DELAY

Extinguishing delay is only useful in normally occupied spaces. For the delay timer settings, there are 3 Dip Switches 6,7 and 8, which can be set in steps of 5 seconds the delay time between 0 and 35 sec.



7 NANO CONTROL PANEL FACIA

The NANO has a clear and orderly front panel, which indicate the system status of the NANO system. The figure shows the controls and LED indicators.



8 CONTROL BUTTONS



8.1 MUTE

The buzzer can be silenced at any time by pressing the Mute button. To silence the external sounder, press the Mute button twice. In case of a second alarm the sounder and buzzer will be activated again.

8.2 RESET

After the cause of the alarm has been determined the NANO can be reset by pressing the Reset button. Manual Call Points, if triggered, must first be reset locally.

8.3 LAMP TEST

All indicators and buzzer can be tested at any time by pressing the **Mute and Reset** simultaneously.

8.4 HOLD EXTINGUISHING RELEASE

By pressing the hold button at the panel or external hold button, as long this button is pressed, the extinguishing release sequence will be halted and cause the yellow hold activated indicator flash. Release the Hold button shall re-start the countdown release timer from programmed time (20 sec).

8.5 AUTOMATIC & MANUAL RELEASE OR MANUAL ONLY MODE

The mode of the system can be toggled between Manual Only and Automatic & Manual by operating the MODE push button on the NANO. When the system is in Manual Only mode, the extinguishant cannot be released by the operation of automatic detectors. To switch the system from manual only to automatic & manual, press the MODE push button for 3 seconds. Return, press the MODE again.

8.6 EXTINGUISHING RELEASE

When a fire emerges, press both front extinguishing release pushbuttons, this will trigger an alarm. The fire extinguishers will be released, depending on the DIP switch (time) settings.



9 LED INDICATORS

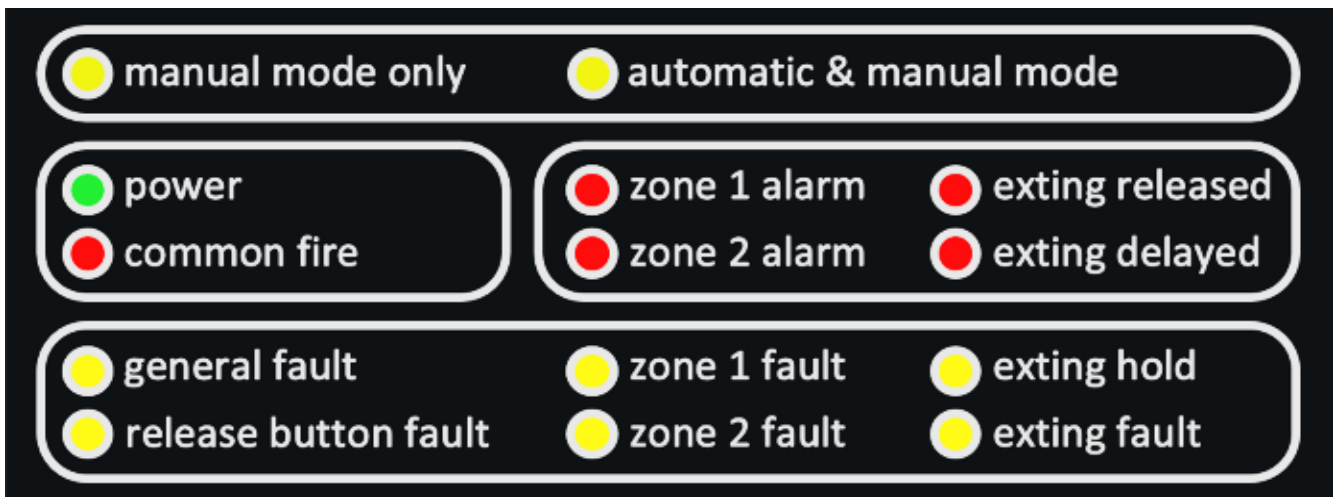

The NANO has 3 internal fault and 14 individual front LED indicators. Under normal condition only the green Power LED and either the Manual Only or Automatic and Manual LED lite.

9.1 MANUAL RELEASE ONLY

The yellow LED manual only lit, the extinguishant will only released by manual action.

9.2 AUTOMATIC & MANUAL RELEASE

The yellow LED automatic & manual lit, the extinguishant is released by automatic detection and/or manual release

9.3 POWER

Under normal conditions the NANO control panel will have only the green power on LED lit and either the manual only or automatic & manual LED lit. Failure of the mains power or disconnection of the backup power will cause a fault. The power LED lite differently, indicating an abnormality in the power supply to the NANO. When starting the NANO after a power failure or an extinguishers release, the green power LED flashes for maximal 1 minute until the system is ready and this LED lit continuously.

If the mains power supply is NOT present, the power LED flashes 1 x per second and the yellow general fault LED lit.

If the standby power supply is NOT present, the power LED flashes 2 x per second followed by a pause of 1 second, then repeating, the general fault and internal battery fault LED lit.

When the vehicle function (DP2) is enabled, the green power LED flashes at a frequency of 90 flashes per minute when switching to secondary voltage.

9.4 COMMON FIRE

In the event of a fire alarm from either the fire alarm detectors or the operation of the extinguishant release pushbuttons, the red general fire LED will lite.

9.5 FIRE ZONE ALARM

Upon receipt a fire alarm condition caused by the activation of a fire detector, the red alarm indicator of the relevant fire alarm zone will flash.



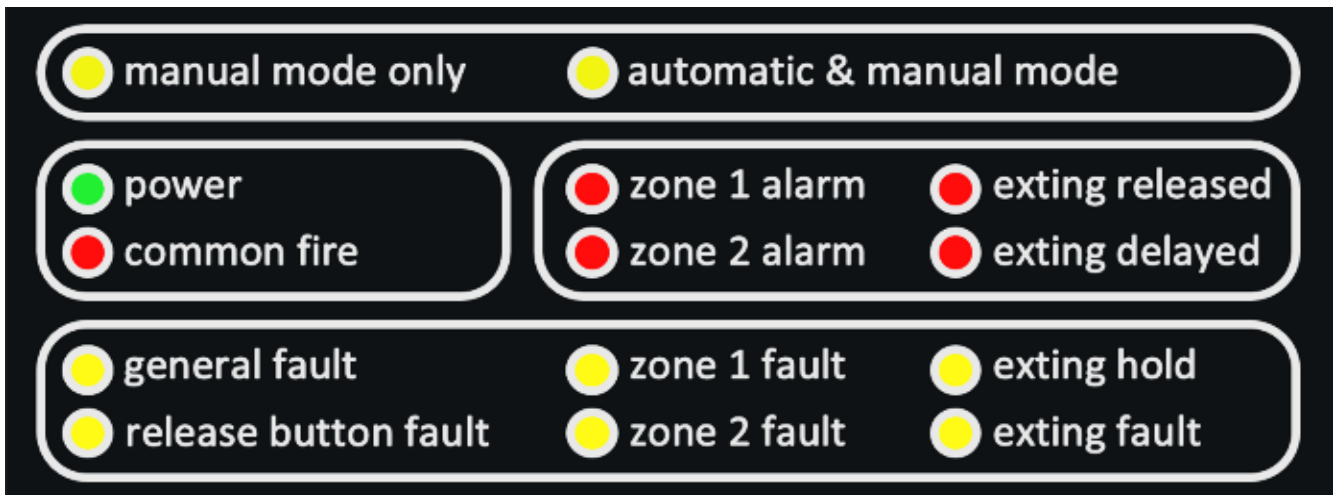

9.6 EXTINGUISHING RELEASED

The red extinguishing released indicator lights continuously when the extinguishers are activated. This extinguishing release indicator lights up after ending of the configured extinguishing delay time, or when the two extinguishing release buttons on the front or the external release button is activated.

9.7 EXTINGUISHING DELAYED

The red extinguishing delayed indicator indicates that the extinguishing release delay is active. This indicator flash when the delay time is running.

9.8 GENERAL FAULT

General fault indicator lights and specific fault indicators flash. This yellow fault indicator will light continuously at any fault condition or power malfunction.

9.9 FIRE ZONE FAULT

When the NANO has detected an error in one of the critical fire detection paths of the system, the specific yellow zone fault indicator flash and the general fault indicator lights up.

9.10 EXTINGUISHING RELEASE HOLD

The yellow hold indicator flash and a different tone sounds as long the hold button on the panel front, or the external hold button is pressed.

9.11 EXTINGUISHING RELEASE FAULT

This yellow indicator lights up continuously when a critical fault is detected (open or short circuit) in the extinguishing output line.

9.12 INTERNAL FAULT INDICATORS

There are three extra yellow fault indicators on the internal electronic PCB, meant for second priority fault messages and these indicators will flash.



10 COMMON SETTINGS

In a marine application, it is NOT common for a fire suppression system intended for an engine room to be released by an automatic fire detector but ONLY by manual release.

The most common Marine setting of the NANO system is based on marine rules and standards. Under normal condition only the green Power LED and the Manual Only LED lite to indicate the system is operating correctly. **Ask your supplier for your system settings.**

Example setting for a vessel's engine room:

- The extinguishing delay time is 20 seconds
- The NANO operate in the manual mode only
- The use of automatic fire detectors is only informative

Example setting for an electronical cabinet or auxiliary space

- The extinguishing delay time is set between 0 and 35 seconds
- The NANO operate in the Automatic & Manual mode
- Dual zone alarm for automatic extinguishing release
- When release delay is programmed, the manual release is also delayed

11 WHAT TO DO RECOMMENDATIONS

11.1 WHAT TO DO IN THE EVENT OF A FIRE ALARM CONDITION

- Carry out the premises defined procedures.
- When it is safe to do so silence the fire alarm devices and reset the system.
- Note the time the fire alarm occurred and log the fire event in the logbook.

11.2 WHAT TO DO IN THE EVENT OF A FAULT CONDITION

- Note the indications on the front of the panel.
- Note the time the fault was noticed and log the fault event in the logbook.
- Notify your service department or company of the fault condition.

11.3 ROUTINE TESTING RECOMMENDATIONS

The required management and maintenance tasks and their frequency may vary by application and Country. It is the responsibility of the Premises Management to undertake periodic tests to ensure the fire detection-/extinguishing system is operational. Record the test results each time in your logbook.

Always ensuring that the system is set to maintenance mode

11.4 WARNING

The N2KB NANO is equipped with two activation techniques for the activation of fire extinguishers. In the (DP3 OFF position) the NANO is set for the activation of electrical igniters meant for aerosol fire extinguishers. In the (DP3 ON position) the NANO is set for activating of an extinguishing system using a solenoid activator. DS 3 OFF = system is meant for electrical igniters intended for aerosol fire extinguishers 1,3A/50ms. With DS 3 ON = system is meant for solenoid activation 24V DC 1 A.

When the DP3 is in the ON position (solenoid only) DO NOT USE it in combination with an ETB.

This may cause irreparably damage to the ETB and the NANO panel.



12 MAINTENANCE RECOMMENDATIONS

12.1 TEST THE NANO SYSTEM WITHOUT ACTIVATING THE EXTINGUISHERS.

Step 1 Open the ETB/BOX

Step 2 Disconnect each extinguisher by using the disconnect switch on each ETB.

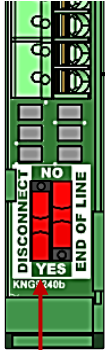
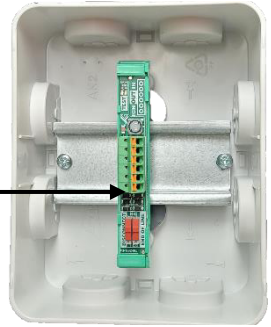

Disconnect extinguisher

Move the disconnect switch of all in the YES position and the aerosol extinguisher is disabled and can not be activated. A disablement will be signaled as fault on the NANO.

Step 3 Activate the extinguishing by pressing simultaneous both yellow extinguishing release buttons on the NANO panel.

Step 4 The confirmation of activation



Confirmation of extinguisher activation

As confirmation of a successful extinguishment activation, the red LEDs on the extinguishers terminal board will flash and the red extinguishing released LED on the NANO front lite up.

Step 5 Reset the system by pressing the reset button on the NANO front.
The FAULT message disappears from the NANO panel.



12.2 TEST THE NANO SYSTEM WITHOUT ACTIVATING THE EXTINGUISHERS

Step 1 Disconnect the extinguisher/s by using the maintenance key switch.
A FAULT message appears to the NANO.

Step 2 Activate the extinguishing by pressing simultaneous the yellow extinguishing release buttons on the NANO panel.

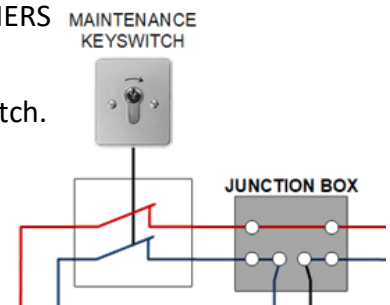

Step 3 The extinguishing release indicator must lite, after the programmed delay time.

Step 4 Restore the system and re-connected the extinguishers using the maintenance key switch.

Step 5 Reset the system by pressing the reset button on the NANO front.
The FAULT message disappears from the NANO panel.

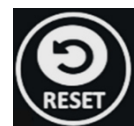

12.3 DAILY TESTING (PREMISES MANAGEMENT)

To be conducted by the Premises Management. Check that the panel shows no fire or fault indications. If there are any fault conditions indicated, then follow instructions in section 11.

12.4 WEEKLY TESTING (PREMISES MANAGEMENT)

To be conducted by the Premises Management.

- Perform a Lamp Test to check that all visual and audible indicators on the panel are functioning.
- When automatic fire detectors are involved bring NANO system in ONLY manual mode
- Test then at least one detector to confirm the operation of the control panel and the audible alarms.
- Carry out an inspection of the extinguishing system according to the instructions of the supplier.

12.5 QUARTERLY TESTING (COMPETENT PERSON)

To be conducted by the Competent Person. Included as reference for the Premises Management.

- Check all previous logbook entries and verify that any corrective actions had been taken.
- Carry out the weekly test.
- Check extinguishers conform the described test method 1 or 2 depending on the availability of test plugs.
- Check the emergency power supply. Disconnect mains power (PSU1) of the NANO and verify that the emergency power (PSU 2) is functioning.

12.6 YEARLY TESTING (COMPETENT PERSON)

To be conducted by the Competent Person. Included as reference for the Premises Management.

- Carry out the quarterly test.
- Test ALL fire detection devices and the manual release and hold buttons.
- The control panel case should be cleaned periodically by wiping with a soft, damp cloth.



Reservations

The policy of N2KB BV is one of continuous improvement and as such we reserve the right to make changes to product specifications at any time and without prior notice. Errors and omissions excepted.

Outdated or replaced computers and electronics are valuable sources for secondary raw materials, if recycled. Dealers of the NANO system must comply with local regulations for waste separation applicable in the country where the supplier is located. Questions concerning the information presented in this manual may be addressed to your dealer.

For technical questions or support contact your dealer for ease contact your extinguishing system supplier.

