

Design Installation Operation Manual



NANO FIRE DETECTION AND EXTINGUISHING CONTROL SYSTEM



TABLE OF CONTENTS

1	DOCUMENT REVISION DETAILS	3
2	SOFTWARE UPGRADE DETAILS	3
3	IMPORTANT NOTES	4
4	WARRANTY	4
5	INTRODUCTION	4
6	ENCLOSURE & INSTALLATION	5
7	MAINTENANCE & CLEANING	5
8	APPENDICES	5
	8.1 APPENDIX A MARINE APPLICATION	5
	8.2 APPENDIX B MASTER / SLAVE CONFIGURATION	5
9	THE NANO	6
10	KEY PROPERTIES	7
11	FEATURES NANO	7
	11.1 ACOUSTIC ALARM	7
	11.2 EXTINGUISHANT RELEASE OUTPUT	7
	11.3 HISTORIC EVENT LOG	8
	11.4 COMMUNICATION PORT	8
	11.5 DIRECT RELEASE	8
	11.6 VEHICLE MODE (NORMALLY NOT IN USE IN MARINE APPLICATIONS)	8
	11.7 GENERAL FAULT RELAY	8
	11.8 VFC FIRE RELAY IN SINGLE OF DUAL MODE	9
	11.9 SINGLE OR DUAL ZONE	9
	11.10 EXTINGUISHANT RELEASE DELAY	9
12	INPUTS	9
	12.1 DETECTION ZONES	9
	12.2 EXTERNAL RELEASE INPUT	10
	12.3 EXTERNAL HOLD INPUT	10
13	OUTPUTS	10
	13.1 VOLT FREE CONTACT RELAY OUTPUTS	10
	13.2 MONITORED EXTINGUISHING OUTPUT	10
	13.3 MONITORED SOUNDER OUTPUT	10
14	CONTROL BUTTONS	11
	14.1 MUTE	11
	14.2 RESET	11
	14.3 LAMP TEST	11
	14.4 HOLD EXTINGUISHING RELEASE	11
	14.5 AUTOMATIC & MANUAL RELEASE OR MANUAL ONLY MODE	11
	14.6 EXTINGUISHING RELEASE	11
15	LED INDICATORS	12
	15.1 MANUAL RELEASE ONLY	12
	15.2 AUTOMATIC & MANUAL RELEASE	12
	15.3 POWER PSU 1 & 2	12
	15.4 COMMON FIRE	12
	15.5 FIRE ZONE ALARM	13
	15.6 EXTINGUISHING RELEASED	13
	15.7 EXTINGUISHING DELAY	13
	15.8 GENERAL FAULT	13
	15.9 FIRE ZONE FAULT	13
	15.10 EXTINGUISHING RELEASE HOLD	13
	15.11 EXTINGUISHING RELEASE FAULT	13
	15.12 INTERNAL FAULT INDICATORS	13

16	DIP SWITCHES	14
16.1	SETTINGS	14
16.2	DIRECT RELEASE (DP1)	14
16.3	VEHICLE MODE (DP2)	14
16.4	EXTINGUISHING RELEASE OUTPUT (DP3)	14
16.5	SINGLE OR DUAL FIRE ALARM (DP4)	15
16.6	VFC RELAY (DP5)	15
16.7	EXTINGUISHING DELAY TIMER (DP6-7-8)	15
17	WIRING DIAGRAM NANO CONNECTED TO IGNITER ACTUATORS	16
18	WIRING DIAGRAM NANO CONNECTED TO AN ETB	17
19	THE ETB	18
19.1	USING THE TWO SWITCHES ON THE ETB	18
20	WIRING DIAGRAM OF THE NANO USING A SOLENOID ACTIVATOR	19
21	NANO WIRING DIAGRAM SOLENOID ACTIVATION SYSTEM	20
22	WIRING & CABLE SPECIFICATIONS:	21
23	TECHNICAL SPECIFICATION	21
24	DEVICES SUPPORTED AND INVOLVED BY THE NANO APPROVAL	22
24.1	DETECTION DEVICE SUPPORT	22
24.2	SOUNDER/BEACON DEVICE SUPPORT	22
25	ENCLOSURE SPECIFICATIONS	22
26	NANO FIRE DETECTOR AND WIRING OPTIONS	23
26.1	APOLLO DETECTOR	23
26.2	FIRECLASS DETECTOR	23
27	NANO LINEAR CABLE HEAT DETECTION	24
28	NANO EXTERNAL EXTINGUISHERS RELEASE & HOLD WIRING OPTIONS	24
29	YL 40 WIRING OPTION SOUNDER & BEACON	25
30	VTB-EM WIRING OPTION SOUNDER & BEACON	25
31	YL 40 WIRING OPTION EXTENDED SOUNDER & BEACONS	26
32	VTB-EM WIRING OPTION EXTENDED SOUNDER & BEACONS	26
33	NANO WITH ETB CONNECTION	27
34	NANO WITHOUT ETB CONNECTION	27
35	NOTES	28

1 DOCUMENT REVISION DETAILS

Issue	Modification Detail	Author	Date
01	1 st publishing document	CvT	01 / 08 / 2022
02	Textual addition chapter 20 (environment & power)	CvT	01 / 09 / 2022
03	Textual addition chapter 22 (specifications extended)	CvT	01 / 03 / 2023
04	Improvement diagram 16	CvT	14 / 04 / 2023
05	Textual addition chapter 5	CvT	01 / 07 / 2023
2.0	Sounder & beacon type expanded, improve diagram	CvT	01 / 07 / 2024
2.1	Add Modbus register	CvT	01 / 08 / 2024

2 SOFTWARE UPGRADE DETAILS

Ver.	Modification Detail	Author	Date
02	1st release Kiwa/Dare EMC test	CvT	01 / 08 / 2022
03	Event log expanded	CvT	01 / 10 / 2022
2.0	Event log expanded	CvT	01 / 07 / 2024
2.1	Add Modbus register	CvT	01 / 08 / 2024

3 IMPORTANT NOTES

This manual should be thoroughly read and understood before installation and/or commissioning of the system is undertaken. The NANO system is not to be regarded as properly used when it is used without regard to any relevant information or advice relating to its use that has been made available by the supplier. The NANO system and the associated connections must be installed, commissioned, and maintained by a skilled, knowledgeable, and competent person or organization that is qualified to perform this work and is familiar with the objective of the equipment and the associated technical terminology. This equipment is not guaranteed unless the complete installation is installed and commissioned in accordance with the laid down local, national and/or international standards.

The NANO/MAR has successfully passed CE and FCC, EMC testing according to EN 50130, EN 61000, EN 55016, 47 CFR15-ICES-003, ANSI 63.4, IEC60945-pt11 and a DNV marine type approval according the DNV Class Guideline 0339-2021, certificate TAA000037H. For that the NANO has endured extensive environmental tests such as vibration, dry & damp heat, and cold tests in accordance with the requirements of the DNV-CG 0339 standard. Where applicable to the NANO, it also meets the requirements of the FSS CODE, the International Maritime Code for Fire Safety Systems.

4 WARRANTY

K&G Groep B.V. represents the NANO system and is free from material defects in materials and workmanship. Our warranty does not cover a NANO system which is damaged, misused, and/or used contrary to the supplied operating manuals or which has been repaired or altered by others. The liability of K&G Groep B.V. is at all times limited to repair or, at K&G's discretion, replacement of the NANO system. K&G Groep B.V. shall not under any circumstances be liable for any indirect, special, or consequential damages such as, but not limited to, damage or loss of property or equipment, cost of de-installation or reinstallation, cost of transport or storage, loss of profits or revenue, cost of capital, cost of purchased or replacement goods, or any claims by customers of the original purchaser or third parties or any other similar loss or damage, whether incurred directly or indirectly. Remedies set forth herein to the original purchaser and all others shall not exceed the price of the NANO system supplied. This warranty is exclusive and expressly in lieu of all other warranties, whether expressed or implied, including, without limitation, any warranties of merchantability or fitness for a particular purpose. The warranty may be void if the equipment is damaged by ESD.

5 INTRODUCTION

The NANO is a very compact and robust stand-alone fire detection-extinguishant release panel designed to protect various applications like electrical cabinets, CNC machines or engine rooms in vessels, yachts. Further all kind of vehicles and other small areas or equipment in which the user should be able to detect and extinguish a fire rapidly and effective. This is done by pressing two buttons, external release button or using fire sensor inputs. The NANO continuously senses its inputs and, in the event of a fire, gives the correct output to enable a product specific fire extinguishing.

In a marine application, it is NOT common for a fire suppression system intended for an engine room to be released by automatic fire detector. By default, the NANO is set to only manual release, but can also be changed to automatic & manual release via push buttons on the front. The NANO is a combined fire detection and extinguishing release system. It has two fire detection zones, any, or all of which can contribute to the extinguishant release decision. The NANO is a versatile fire alarm extinguishing release system with a high-performance level.

6 ENCLOSURE & INSTALLATION

The NANO control panel should be mounted on a dry, flat surface, at eye height in a horizontal position so that the enclosure cannot be deformed. The NANO should be installed in an accessible area. Take into consideration environmental factors such as high temperatures. The enclosure is provided with 7 predrilled holes for cable glands. 2 x M16 and 5 x M12. To ensure IP rating the cables must be brought in using the appropriate cable glands. Dimensions enclosure 120 x 80 x 58,5 mm w x h x d.



7 MAINTENANCE & CLEANING

There are no user-replaceable parts in the NANO. Take Electrostatic Discharge (ESD) precautions when opening the NANO. Always wear a properly grounded anti-static wrist strap. Avoid direct contact with any of the components or connectors connected to the printed circuit board. Never let the electronics come in contact with clothing. The ground strap cannot dissipate static charges from fabrics. Failure to follow accepted ESD handling practices could cause damage to the NANO.

Before starting the cleaning process, bring the system out of operation to prevent an unwanted fire extinguishing system release. The NANO fire detection-/ extinguishing release panel has an IP rating of 65. The IP rating system uses a 2-digit system to define its protection rating for all products. The first digit represents protection against solids and the second against liquids. The six stands for totally dust tight, with full protection against dust and other particulate. The five stands for protection against low-pressure jets (6.3 mm) of directed water from any angle (limited ingress permitted with no harmful effects). This IP rate concerns the housing and is only and exclusively applying if the correct mounting method is used, and the correct glands are fitted and assembled. It is important to note that improper cleaning of the NANO front can damage this panel inhibit their ability to sense fire and activate the fire extinguishers. To remove dust and contaminants, use nonalcoholic products which has been designed for that purpose.

DON'T USE HIGH PRESSURE WASHERS OR STEAM CLEANERS

It will certainly damage the front foil with the control buttons and indication LEDs.

8 APPENDICES

For special applications and functions, appendices are available that have a direct relationship to this manual. Please refer to the technical instruction of this manual and the appendices in case of a marine and/or master slave application.

8.1 NANO/MAR/BASIC

8.2 NANO/MAR/MASTER / SLAVE CONFIGURATION

9 THE NANO

The NANO is not only developed for land based installations, but can also be applied in marine applications. It has a DNV-CG Type Approval in accordance with the 0339 CG standard. NANO system consists of two components. The basis is formed by the NANO control panel which is placed on the bridge or in its vicinity. Then there is an extinguisher terminal board (ETB). This ETB must be placed, in a proper enclosure, outside, but in the immediate vicinity of the to protected engine room. **ETB/L** is suitable for an extinguisher igniting actuator with a maximum resistance of $<2\Omega$. The **ETB/H** is suitable for an extinguisher igniting actuator with a maximum resistance of $>2\Omega$. From the ETB a cable led to the aerosol extinguisher installed in the volume to be protected. The cable connection between the NANO control panel and the fire extinguisher ETB is continuously scanned on faults, such as short circuit or cable break. From the extinguishers



terminal board (ETB) to the extinguisher's igniter is also monitored on fault or malfunction. **In a marine application, it is NOT common that a fire suppression system intended for an engine room protection is released by an automatic fire detector.** However, the NANO has two fire alarm zones suitable for connecting marine approved fire detectors such as the Apollo Orbis Marine series fire detectors. The NANO system

can be set up so that fire alarms from these fire detectors, signaled on the NANO panel, are considered as informative only. Then they will not have any effect on the extinguishing system, nor activate the extinguishing system. BY default, the NANO is set to only manual release, but can be changed to automatic & manual mode. Then they will have effect on the extinguishing system and be able to activate the extinguishing system.

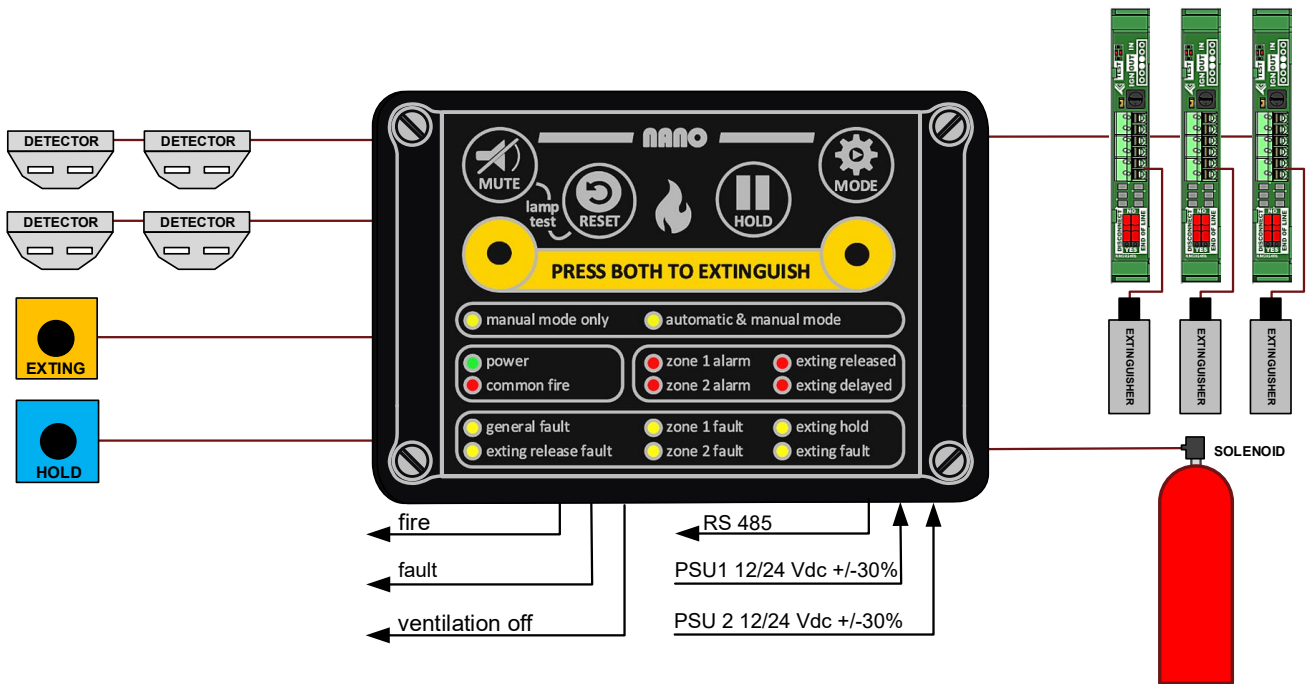

10 KEY PROPERTIES

- Able to set to manual, single stage or double stage detection, alarm, and extinguishing
- Outputs for fire, fault, ventilation off and visual & acoustic alarm device
- A full monitored output for the aerosol fire extinguishing generators
- Two full monitored fire alarm input groups (zones) for linear heat and / or int detectors
- Two full monitored alarm input groups for external extinguishing release and hold function
- Double extinguisher release buttons to prevent unwanted releases
- Extinguishers hold release button to postpone releases
- Extinguisher release delay to prevent unwanted releases
- Extinguishing delay which can be set between 0 and 35 seconds
- Additional option to override the release extinguishing delay after manual release
- Additional functionality regarding separated external hold-off functions
- Additional functionality regarding separated external release extinguishing functions
- Historic event log memory readable from a mini-USB port
- Modbus RS485 communication port
- The NANO works on input voltage 8 to 28 Volt DC
- The NANO has an IP 65 waterproof enclosure, with cable glands
- ESD and EMC protected, and CE and FCC marked.
- DNV-CG type approval; according the 0339 DNV-CG standard

11 FEATURES NANO

11.1 ACOUSTIC ALARM

The NANO has an internal attention signal and a monitored output for an external sounder/beacon. Malfunctions are standard signaled with a continuous tone signal, alarms with a pulsating tone signal. Deviating tone signaling takes place with extinguishing activation and operation of the hold (extinguishing delay) function. The voltage of the monitored output to drive an additional sounder/beacon is controlled by the NANO and is independent of the main power supply voltage.

11.2 EXTINGUISHANT RELEASE OUTPUT

The NANO is equipped with two activation techniques for the activation of fire extinguishing systems. The selection can be made using DIP switch 3. By default, the NANO is programmed for the activation of electrical igniters intended for aerosol fire extinguisher generators, with DIP switch 3 in the OFF position. The activation of aerosol fire extinguisher units is actuated by means of a current pulse of 1.3A for 50ms.

When DIP switch 3 is placed into the ON position, then the NANO is suitable for activating a fire extinguishing system that makes use of a solenoid as actuator of the fire suppression system. The activation voltage is then 24V DC with a maximum of 1A.

IMPORTANT

For the default current pulse activation method (DP3 OFF) the NANO supply voltage, meant for electrically activatable aerosol fire extinguisher units, is 12V to 24Vc +/-30%. For the voltage-controlled activation (DP3 ON), the NANO supply voltage, meant for an extinguishing system that uses a solenoid actuator, is 24VDC.



11.3 HISTORIC EVENT LOG

The NANO has an historic event log memory of 10.000 events readable from a USB port. Connect an USB cable between the Mini-B USB port and your computer. The device will act as an USB stick. Your operating system will create a new disk station. The files on the disk station are text files with logged event. The event log system is only meant for viewing, monitoring, and analyzing. The events are recorded without time and date but in order of event. Each time the NANO reboots, a new file is created with a new batch number in the name. Pressed control buttons, detailed alarm and fault indications, and relay switching events are logged in the text files.



11.4 COMMUNICATION PORT

The NANO has a Modbus network connection. Modbus enables communication among devices connected to the same network. A Modbus network consists of one master and a number of slaves units, each with a unique address. For more information, see the MODBUS user manual.

11.5 DIRECT RELEASE

When the timer settings are set to a delay (between 10 – 35 seconds), the direct extinguish DIP switch gives the choice to override the delay in case of a fire event. If a fire alarm is detected, by the automatic fire detectors of the NANO and the count-down timer is started, you can override the timer. By pressing the dual release extinguishing buttons on the front of the panel or the external release extinguishing button, the extinguishing releasing process starts without delay immediately. This function can be selected via DIP switch 1.

11.6 VEHICLE MODE (NORMALLY NOT IN USE IN MARINE APPLICATIONS)

If the extinguishing system is intended for the protection of a vehicle engine bay, then a programmed extinguishing delay must be disabled, when the vehicle is parked, and the driver leaves the vehicle. A fire extinguisher delay is then of no use and should be overridden. As soon as the ignition switch is used again, even for a very short moment, the system returns to the programmed state. In vehicle mode, a single or dual (depending on the DIP switch) fire alarm immediately release the extinguishers without delay. In normal operation, the vehicle power the NANO at terminals 15 + and 14 -, which means that the engine is switched on. In vehicle mode, the + on connection point 15 must be extended with a + on connection point 13. If the vehicle is parked and the driver removes the car key from the ignition lock, then this should remove the voltage at point 13 and thus eliminate any delay. When the vehicle function (DP2) is enabled, the green power LED flashes at a different frequency than when switching to secondary voltage. When the vehicle mode is not in use and there is no external backup battery/power supply available, connect battery inputs 17 and 18 in parallel on respectively the power terminals 14 and 15 to avoid a battery failure signal. This function can be selected via DIP switch 2.

Please note that the vehicle mode does not work in the only manual mode (12.5)

11.7 GENERAL FAULT RELAY

The general fault relay signals any fault in the NANO. The fault relay is normally energized and will de-energize upon any fault condition including total loss of power. This secures a complete fail-safe condition of the NANO panel in case of a fault condition.

11.8 VFC FIRE RELAY IN SINGLE OF DUAL MODE

A single or dual FIRE indication can trigger the VFC relay. In the single mode the VFC relay will be activated when one of the fire zones have a fire alarm condition. In the dual mode this relay shall be activated after both fire zones have a fire alarm condition. This function can be selected with DP 5.

11.9 SINGLE OR DUAL ZONE

Usually, the extinguishing system is activated in the so-called two group-dependent status (avoiding coincidence). Two fire conditions must be received before an extinguishing activation will be initiated. In some cases, a single mode status can be handy. In dual (standard) mode the extinguisher(s) shall be released after both detection zones will have a fire alarm condition and cause an internal pulsing alarm sound. The fire relay and extinguisher are activated according to the DIP switch settings. In single mode the extinguisher(s) will be released when one detection zone is in fire alarm condition and cause an internal pulsing alarm sound. The fire relay and extinguisher are activated according to the DIP switch settings. This function can be selected via DIP switch 4.

11.10 EXTINGUISHANT RELEASE DELAY

Extinguishing delay is only useful in normally occupied spaces. For the delay timer settings, there are 3 Dip Switches 6,7 and 8, which can be set in steps of 5 seconds the delay time between 0 and 35 seconds. The countdown timer is used to wait a certain amount of time before extinguisher/s are activated.

12 INPUTS

The NANO is equipped with two detection zones and two external button inputs (Extinguishing Release & Hold). These inputs are continuously scanned for alarm or fault detection. All inputs are monitored and require a 10 k Ω end of line resistor, even if the input is not used. The button inputs must have a trigger resistor between 470 and 1000 Ω .

12.1 DETECTION ZONES

The NANO is equipped with two fire detection zone inputs. The loop inputs are continuously scanned for fire or fault detection. The loops are set to the following values:

- RESISTANCE of less than 100 Ω : FAULT
- RESISTANCE of more than 100 Ω and less than 1,5 k Ω : FIRE
- RESISTANCE of more than 1,5 k Ω and less than 8 k Ω : FAULT
- RESISTANCE of more than 8 k Ω and less than 12 k Ω : NORMAL
- RESISTANCE of more than 12 k Ω : FAULT

When a low resistance (less than 450 Ω) linear heat cable is used, a 470 Ω resistor must be installed in series at the begin of the loop on one of the wires. Otherwise, the wires of the linear heat cable which will give a fault instead of a fire alarm. Contrary to the linear heat cable, when using a Fenwal or equal thermal heat detector, a resistor of 470 Ω must be placed in series with the alarm contact, an end of line resistor 10 k Ω in parallel over the alarm contact and 470 Ω resistor. The maximum number of detectors in one zone is 4. The voltage of all monitored detection inputs is controlled by the NANO and is independent of the main power supply voltage. The NANO alarm zones 1 and 2 operate in the quiescent state with a voltage of 15 VDC. Each input zone needs an EOL resistor of 10 k Ω , even if the fire zone is not used.

12.2 EXTERNAL RELEASE INPUT

The NANO has a separate input for an external extinguishing release button. The external extinguishing release button has the same function as the dual extinguishing release buttons on the front of the panel. By pressing the external extinguishing release button, the fire extinguisher(s) will be released. Depending on the Dip switch (time) settings it is possible to delay the release. The delay time can be set from 0 to 35 seconds in steps of 5 seconds. These loop inputs are continuously scanned for alarm or fault conditions.

12.3 EXTERNAL HOLD INPUT

The NANO has a separate input for an external extinguishing release hold button. The external extinguishing release hold button has the same function as the internal extinguishing release hold button. When an alarm is active and the hold button is pressed, the extinguisher release delay time will be halted. Release of the Hold button shall re-start the countdown release timer from maximum.

13 OUTPUTS

The NANO is equipped with 5 outputs, two monitored and three potential free. The monitored outputs are continuously scanned for open and short circuit fault conditions. The potential free outputs have a contact load of 30 VDC /1A. The monitored outputs are for the extinguishing output (extinguishing release) and for the electronic sounder/beacon output.

13.1 VOLT FREE CONTACT RELAY OUTPUTS

Contact load relays 30 VDC 1A.

- **1 relay output general fire alarm.** The general fire relay will energize upon activation of a fire detection in any of the fire zones or by pressing of the in-/external extinguishing release buttons.
- **1 relay output general fault message.** The general fault relay signals the presence of a fault in the NANO. In the event of a complete power failure, the general fault relay will be activated.
- **1 relay output at 1st or 2nd fire alarm.** VFC relay output is programmable for 1st or 2nd fire alarm and intended, among other things, for switching off ventilation and/or air conditioning of the area to be protected.

13.2 MONITORED EXTINGUISHING OUTPUT

THE NANO is equipped with a fire extinguisher output monitored for short circuit and wire breakage. In combination with the ETB (Extinguishers Terminal Board), the NANO's extinguishing output is protected against reverse polarity and equipped with surge protection. **Without** the use of an ETB, this extinguishing activation output is NOT protected against surge and reverse polarity and covered by the manufacturer's warranty. If the ETB is not used then an end of line diode is required (1N5400, 1N4007, RL201, SF21). Read also chapter 19/34.

13.3 MONITORED SOUNDER OUTPUT

This output, intended for the optical and/or acoustical alarm device, is monitored for short circuit and wire break by placing a 10 K Ω end-of-line monitoring resistor of the alarm device such as on the VTB-32EM or YL 40 sounder/beacon see schedules sheet at 26 and 27. At some sounders the end of line resistor is not necessary, because the resistance of the sounder input is sufficient enough to monitor on short circuit and/or wire break.

14 CONTROL BUTTONS

The NANO has a clear and orderly front panel with which the system status of the NANO can be determined rapidly. The figure shows the controls and indications with text. The NANO facia consists of a special foil with embedded the control buttons and LED indicators.

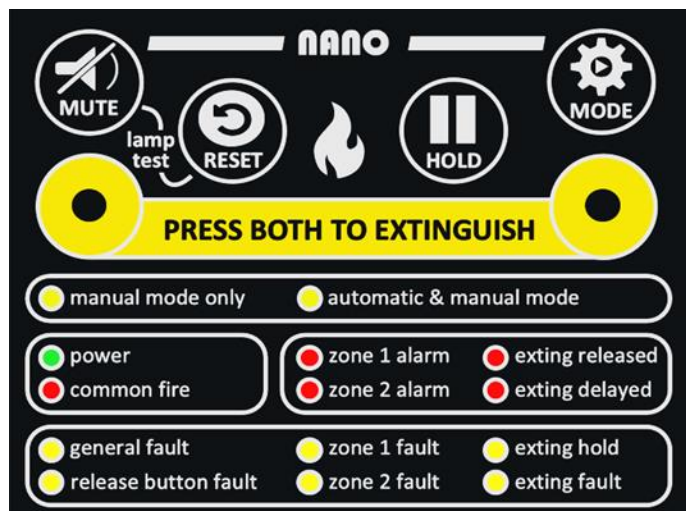

14.1 MUTE

The buzzer can be silenced at any time by pressing the Mute button. To silence the external sounder, press the button twice. **It is not permitted to disable the external sounder in the extinguishant release state.**

In the event of a 2nd alarm, the sounder and buzzer are activated.

14.2 RESET

After the cause of the alarm has been determined the NANO can be reset by pressing the Reset button. Manual Call Points, if triggered, must first be reset locally. Fault indications are self resetting type and vanished automatically when the fault condition is removed.

14.3 LAMP TEST

All indicators and buzzer can be tested at any time by pressing the **Mute and Reset** simultaneously.

14.4 HOLD EXTINGUISHING RELEASE

By pressing the hold button at the panel or external hold button, as long this button is pressed, the extinguishing release sequence will be halted and the yellow hold activated indicator flash, and the buzzer sound pulsating. When the control panel is in the second stage alarm condition and the hold function is activated, the extinguishing release sequence will be halted, the second stage sound shall change to first stage sound. Release the Hold button shall re-start the countdown release timer from maximum.

14.5 AUTOMATIC & MANUAL RELEASE OR MANUAL ONLY MODE

The mode of the system can be toggled between Manual Only and Automatic & Manual by operating the MODE push button on the NANO. When the system is in Manual Only mode, the extinguishant cannot be released by the operation of automatic detectors. In that mode the automatic fire detectors are only informative. To switch the system from manual only tot automatic & manual press the MODE push button for 3 seconds. To return the system to manual mode only, press the MODE push button again for 3 seconds.

14.6 EXTINGUISHING RELEASE

When a fire emerges, press both front extinguishing release pushbuttons simultaneous, this will trigger an alarm. The fire extinguishers will be released, depending on the DIP switch (time) settings.

15 LED INDICATORS

The front of the NANO has 1 common fire, 3 internal fault, and 13 individual LED indicators on the front divided in three sections to indicate general functions, fire alarm and the extinguishing status. Under normal state, control panel will have only the green, Power LED lite and either the Manual Only or Automatic and Manual LED lite. The yellow fault LEDs automatically turn off when the cause of the fault is recovered.



15.1 MANUAL RELEASE ONLY

When the yellow "manual mode only" LED lit, the extinguishing agent is not released by automatic fire detectors, but **only** by manual operation.

15.2 AUTOMATIC & MANUAL RELEASE

When the yellow LED "automatic and manual mode" is on, the extinguishing agent is released by the automatic fire detectors **and/or** manual operation.

15.3 POWER PSU 1 & 2

PSU 1 = mains and PSU 2 = backup. Under normal conditions the NANO control panel will have only the green, power on LED lit and either the manual only or automatic & manual LED lit. Failure of the mains power or disconnection of the backup power will cause a fault. The power LED lite differently, indicating an abnormality in the power supply to the NANO. When starting the NANO after a power failure or an extinguishers release, the green power LED flashes for maximal 1 minute until the system is ready and this LED lit continuously.

If the **mains** power supply is NOT present, the secondary power supply takes it over, the power LED flashes 1 x per second, the yellow general fault LED lit, the common fault relay will be deactivated.

If the **standby** power supply is NOT present, the power LED flashes 2 x per second followed by a pause of 1 second, then repeating, the general fault and internal battery fault LED lit, the common fault relay is deactivated.

If a **standby power source is not available**, then the connection points 17/18 must be connected to respectively point 14/15 to avoid a fault message.

When the **vehicle function (DP2)** is enabled, the green power LED flashes at 1 x per second when vehicle is parked and switch to the secondary vehicle voltage.

15.4 COMMON FIRE

In the event of a fire alarm from either the fire alarm detectors or the operation of the extinguishant release pushbuttons, the red general fire LED lit.

15.5 FIRE ZONE ALARM

Upon receipt a fire alarm condition caused by the activation of a fire detector, the red alarm indicator of the relevant fire alarm zone will flash. The common fire indicator will always accompany this, and the internal buzzer sounds pulsating.

15.6 EXTINGUISHING RELEASED

The red extinguishing release indicator lights continuously when the extinguishers are activated. This red extinguishing release indicator lights up after ending of the configured extinguishing release delay time, or when the two extinguishing release buttons on the front are pressed or the external release button is activated. A tone sounds when the extinguishing has released.

15.7 EXTINGUISHING DELAY

The red extinguishing delay indicator indicates that the extinguishing release delay is active. This indicator flash when the delay time is running. This indicator will light continuously when pressing the hold button. When the hold button is released, the indicator shall flash again and re-start the countdown release timer from maximum. This indicator turns off when the delay time has elapsed, and the extinguishing release has taken place.

15.8 GENERAL FAULT

General fault indicator lights and specific fault indicators flash. This yellow fault indicator will light continuously at any fault condition.

15.9 FIRE ZONE FAULT

When the NANO has detected an error in one of the critical fire detection paths of the system, the specific yellow zone fault indicator flash and the general fault indicator lights up. The internal buzzer sounds pulsating.

15.10 EXTINGUISHING RELEASE HOLD

The yellow hold indicator flash and a different tone sounds as long the hold button on the panel front, or the external hold button is pressed. This yellow hold indicator is turns off when the hold button is released.

15.11 EXTINGUISHING RELEASE FAULT

This yellow indicator lights up continuously when a critical fault is detected (open or short circuit) in the extinguishing output line. This yellow indicator will turn off when the cause of this malfunction has been rectified.

15.12 INTERNAL FAULT INDICATORS

There are three extra yellow fault indicators on the internal electronic PCB, meant for second priority fault messages and these indicators will flash.

- LED 1 signals a fault in the monitored sounder/beacon line
- LED 2 signals a fault in the external extinguishing release hold input
- LED 3 signals a fault in the emergency power source PSU 2

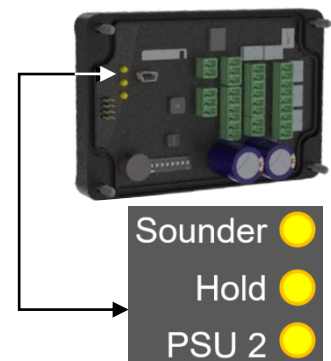

16 DIP SWITCHES

16.1 SETTINGS

Standard setting ex factory, all dipswitches in OFF position.

- Automatic fire detector as the initiators of an extinguishing action is the standard, no override the delay timer.
- The vehicle mode is disabled
- Activation of electrical igniters for aerosol fire extinguishers
- Dual zone alarm for automatic extinguishing release.
- VFC relay activate at 2nd fire alarm
- Extinguishant release delay 0 seconds

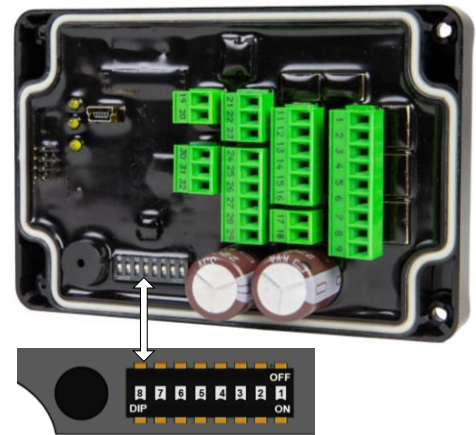

Recommended setting for marine application with manual release only:

- Front NANO manual release ONLY, fire detectors are not in use (DP1 OFF)
- The vehicle mode is disabled is not in use (DP 2 OFF)
- Activation of electrical igniters for aerosol fire extinguishers (DP 3 OFF)
- Dual zone alarm is not in use (DP 4 OFF)
- VFC relay activate at 1st (DP 5 ON)
- Extinguishant release 20 seconds (DP 6 ON - DP 7 OFF - DP 8 OFF)

16.2 DIRECT RELEASE (DP1)

If a fire alarm is detected, by the automatic fire detectors the countdown timer is started, you can override the timer when press the manual release. DS 1 OFF = extinguishing delayed also in manual operation if a delay has been programmed.

DS 1 ON = extinguishing without delay in manual operation.

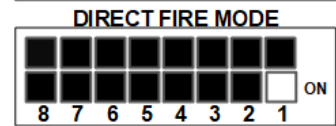
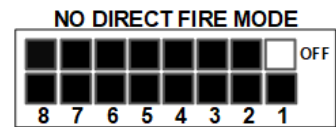

16.3 VEHICLE MODE (DP2)

If the extinguishing system is intended to protect the engine compartment of a vehicle, a programmed extinguishing delay must be disabled when the vehicle is parked, and the driver leaves the vehicle.

DS 2 OFF = system behaves as programmed with delay.

DS 2 ON = delayed extinguishing is disabled when parked.

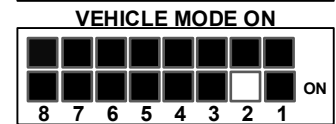
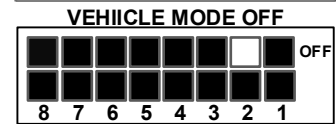

16.4 EXTINGUISHING RELEASE OUTPUT (DP3)

The K&G Groep BV NANO is equipped with two activation techniques for the activation of fire extinguishing systems. Standard (DP3OFF) the NANO is programmed for the activation of electrical igniters intended for aerosol fire extinguisher units. When DIP switch 3 is set to the ON position, the NANO is suitable for activating an extinguishing system using a solenoid

DS 3 OFF = system is suitable for electrical igniters intended for aerosol fire extinguishers 1,3A/50ms
DS 3 ON = system is suitable for solenoid activation 24V DC 1 A

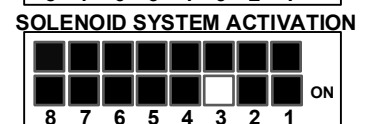
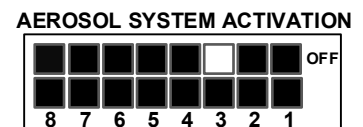

WARNING

When the DP3 is in the ON position (solenoid only) DO NOT USE it in combination with an ETB. This may cause irreparably damage to the ETB and the NANO control panel.

16.5 SINGLE OR DUAL FIRE ALARM (DP4)

Normally we work in dual fire zone mode. In some cases, a single mode state can be useful. In dual mode, the extinguisher(s) are released after an alarm condition is detected in both fire zones. In single mode, the extinguisher(s) are released when one fire zone is in alarm.

DS 4 OFF = automatic extinguishment activation with 2 fire zones in alarm.

DS 4 ON = automatic extinguishing activation with 1 fire zone in alarm.

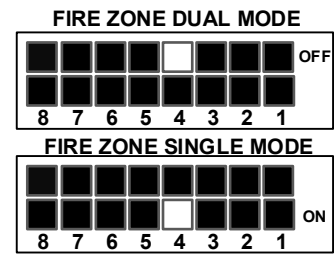

16.6 VFC RELAY (DP5)

Here one has a choice to have the relay active at the first fire alarm or after the second fire alarm.

DS 5 OFF = VFC relay active with 2nd fire alarm.

DS 5 ON = VFC relay active with 1st fire alarm.

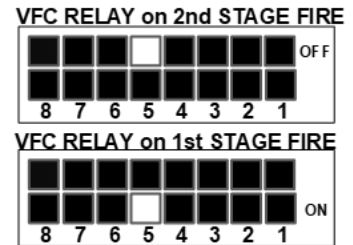

16.7 EXTINGUISHING DELAY TIMER (DP6-7-8)

Extinguishing delay is only useful in normally occupied spaces. For the delay timer settings, there are 3 DIP switches, which can be set between 0 and 35 seconds, with steps of 5 seconds. The count-down timer is used to wait a certain amount of time before extinguisher is activated. This timer can be set with the use of the timer DIP switches 6,7 and 8.

DS 6 OFF |

DS 7 OFF | - is no delay

DS 8 OFF |

DS 6 OFF |

DS 7 OFF | - is 5 seconds delay

DS 8 ON |

DS 6 OFF |

DS 7 ON | - is 10 seconds delay

DS 8 OFF |

DS 6 OFF |

DS 7 ON | - is 15 seconds delay

DS 8 ON |

DS 6 ON |

DS 7 OFF | - is 20 seconds delay

DS 8 OFF |

DS 6 ON |

DS 7 OFF | - is 25 seconds delay

DS 8 ON |

DS 6 ON |

DS 7 ON | - is 30 seconds' delay

DS 8 OFF |

DS 6 ON |

DS 7 ON | - is 35 seconds delay

DS 8 ON |

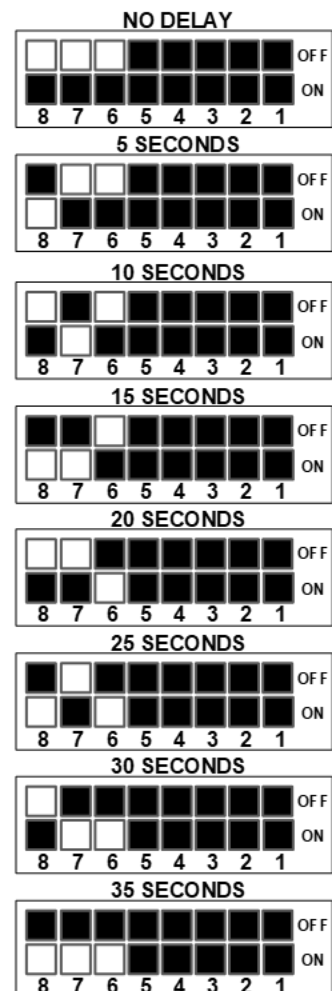

17 WIRING DIAGRAM NANO CONNECTED TO IGNITER ACTUATORS

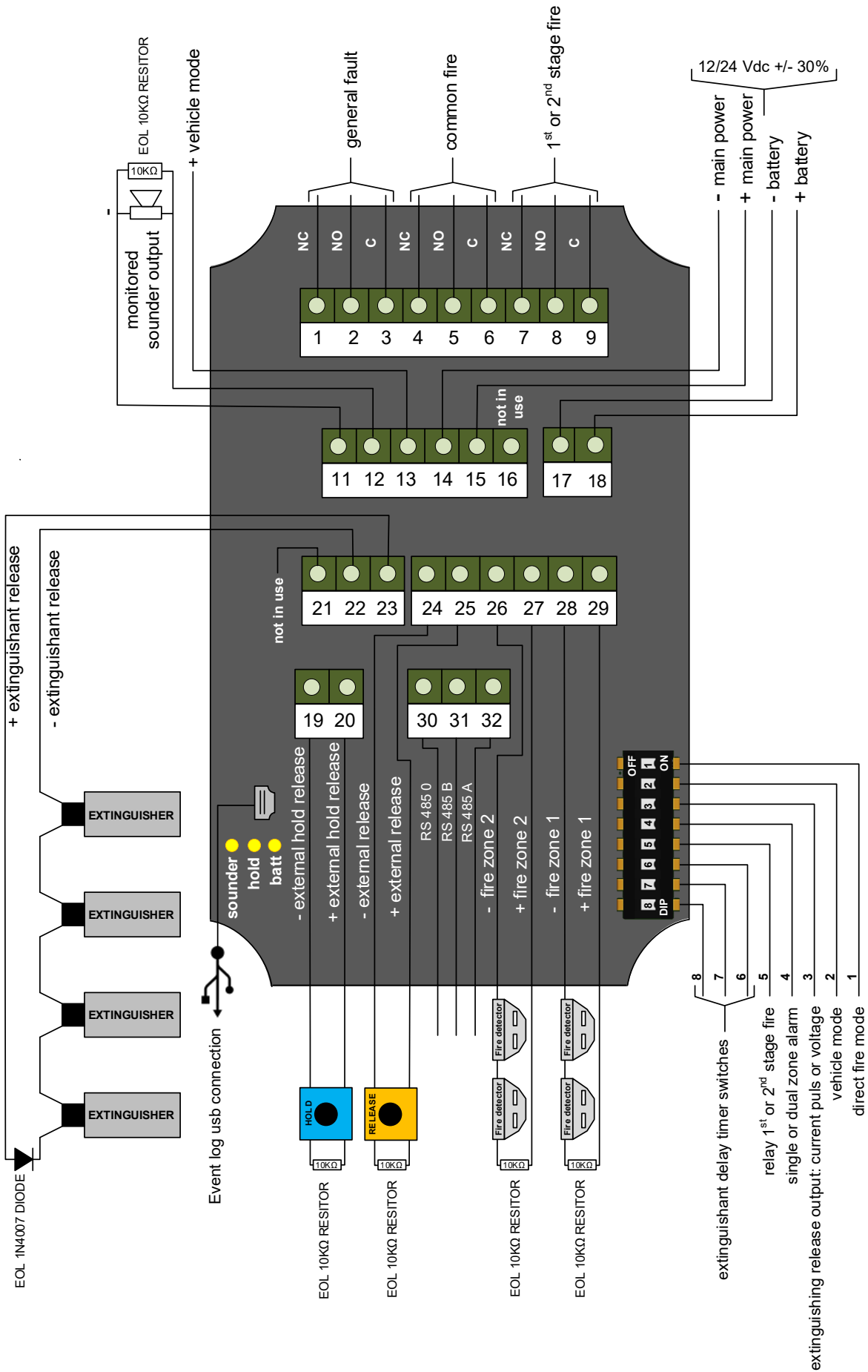

18 WIRING DIAGRAM NANO CONNECTED TO AN ETB

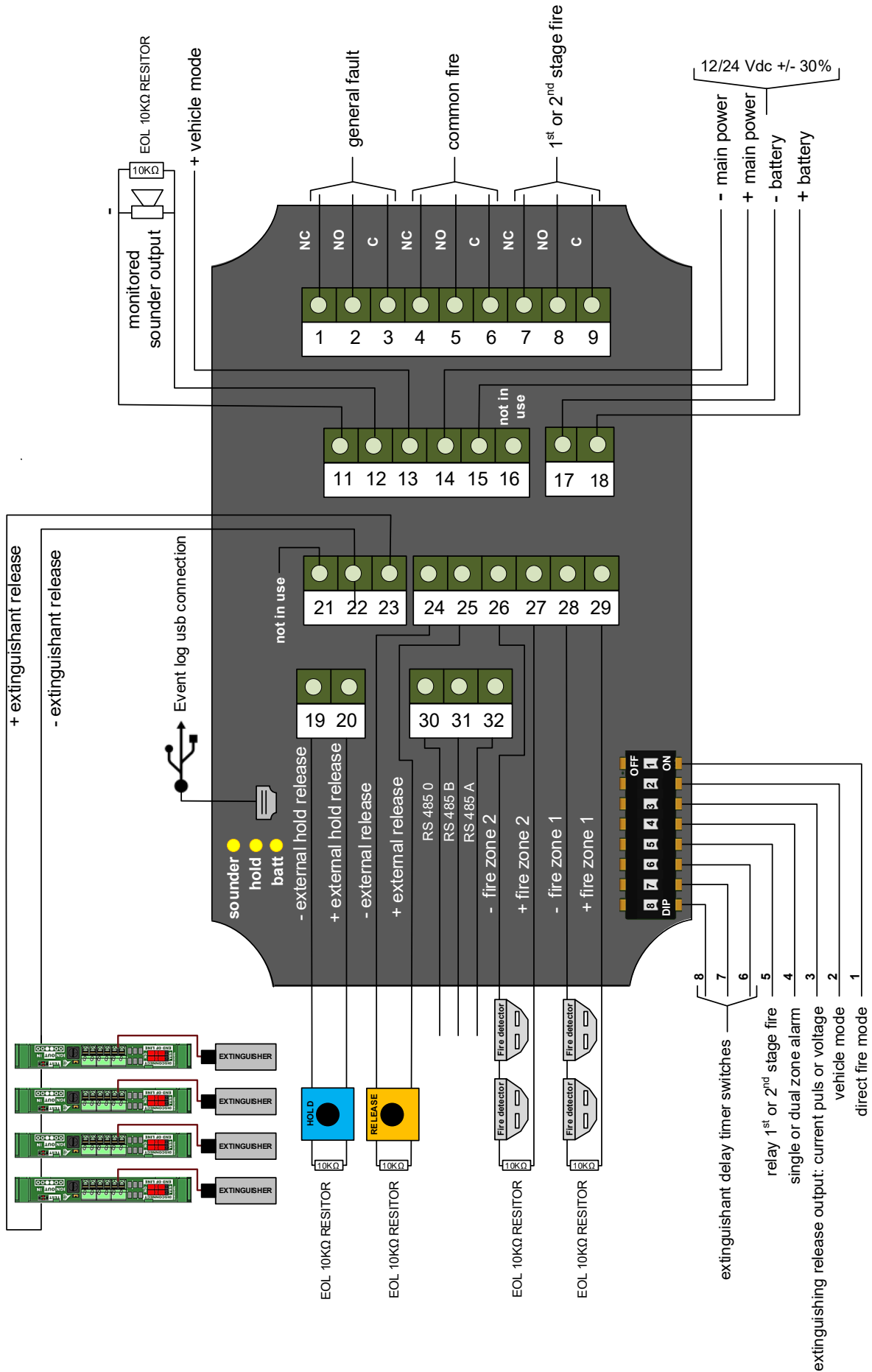

19 THE ETB

The ETB is specially developed for connecting aerosol extinguishers. This terminal connection board is equipped with built-in security electronics, which ensures that all igniters of the extinguishing units are activated. Together with an end line switch, this option turns the NANO system into a complete and reliable fire detection and extinguishing system.

The most important characteristics of the ETB are:

- simple push-in connection technology
- minimum core diameter 0.5 mm² (AWG 20)
- maximum core diameter 1.5 mm² (AWG 16)
- a bridging protection ensures that the ignition current flows through ALL electrical activators for at least 50 ms, also when one of the igniters is malfunctioning or behaving differently than others (eg. Ignite sooner and going in high impedance before other igniters have been ignited)
- the ETB is equipped with a switch that activates the end-line monitoring diode on the last extinguishing generator
- a second switch is intended to disconnect the electrical activator from the extinguishing line for the purpose of testing the extinguishing line without activating the extinguishing generators
- there is a red test LED that shows that an activation current is actually being initiated during the installation test
- the ETB is equipped with reverse polarity protection, thereby avoiding connection errors
- the ETB is equipped with surge protection, which reduces the risk of activation of a fire generator near a lightning strike
- mounting method: DIN rail 35 mm

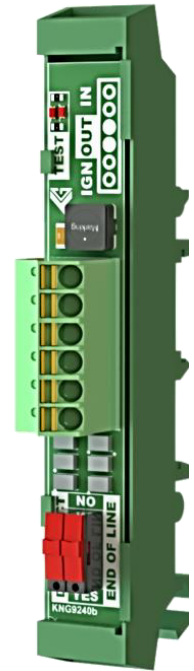

19.1 USING THE TWO SWITCHES ON THE ETB

Incorrect placement of the end line switch makes it possible to disable a part of the extinguisher's activation circuit. Therefore, a visual inspection is an essential part of the commissioning and maintenance engineers' work. This visual inspection must be a standard provision in the commissioning regulation.

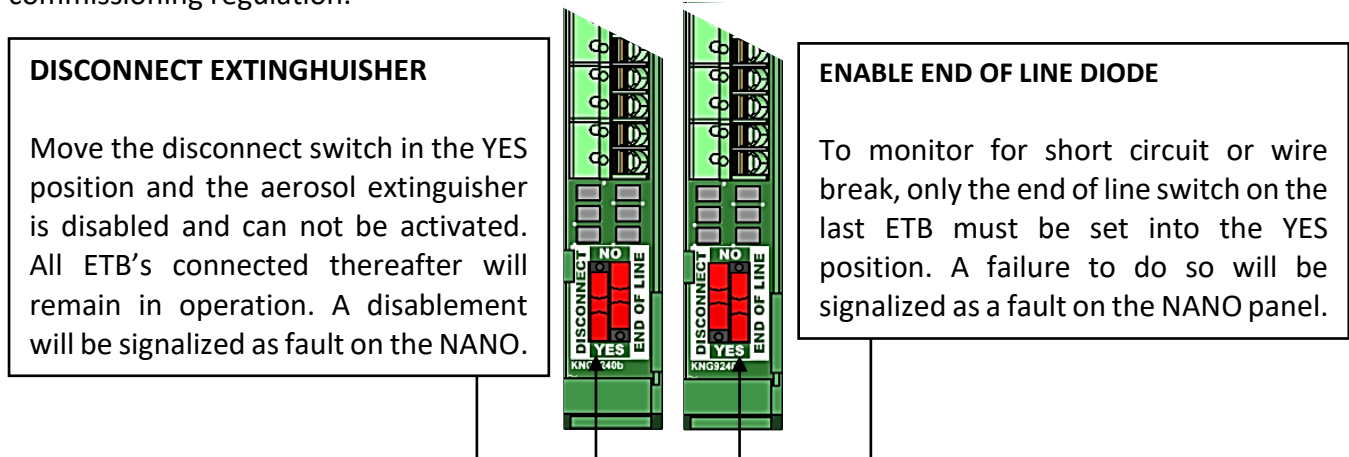

20 WIRING DIAGRAM OF THE NANO USING A SOLENOID ACTIVATOR

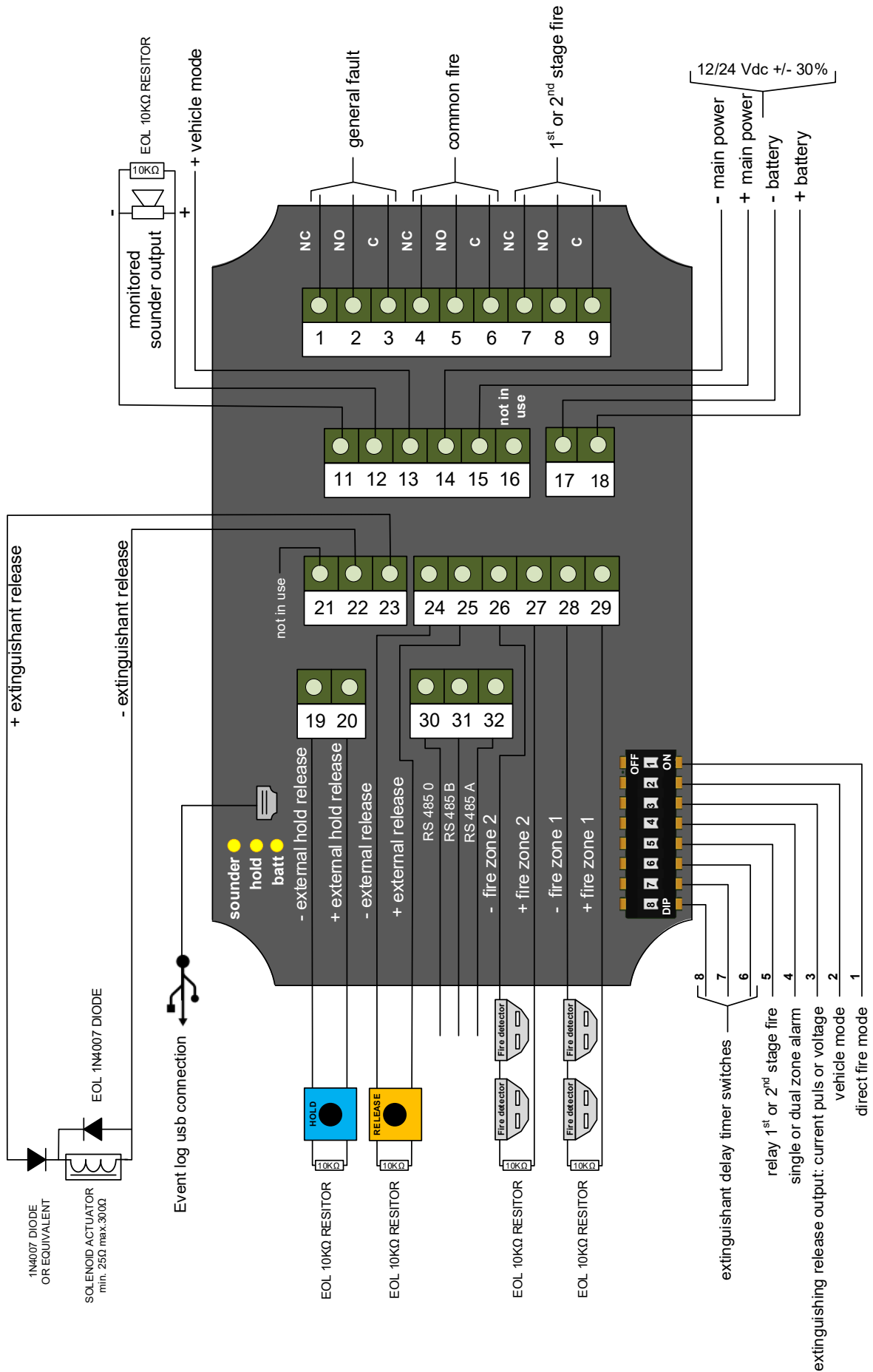

21 NANO WIRING DIAGRAM SOLENOID ACTIVATION SYSTEM

In addition to a fire extinguishing output for electric igniters meant for aerosol fire extinguishing generators, the NANO also has an extinguishing output suitable for a solenoid-controlled fire extinguishing system.

The extinguishant output is capable to supply up to 1 Amp for the maximum duration to a solenoid. Solenoids must have a resistance of 25 to 200 ohms 18/28V DC, to ensure that the maximum current rating of the extinguishant output is not exceeded. The maximum cable impedance is 1.5Ω-5.0Ω depending on the coil impedance.

Calculate the voltage drop across the cable to ensure that sufficient voltage remains at the end of the control cable for the activation of the solenoid activator.

The solenoid should be fitted with two diodes. One diode for the end of line monitoring. The other is a flyback diode. A fly back diode is a diode connected across the coil used to eliminate flyback, which is the sudden voltage spike seen across an inductive load when its supply current is suddenly reduced or interrupted. It is used in circuits with a possible inductive load. **IMPORTANT**

Despite the presence of a button on the NANO front for manual extinguishing activation only, we do recommend a service/maintenance key switch in the extinguishing output line to perform test and maintenance work without activating the extinguishing system.

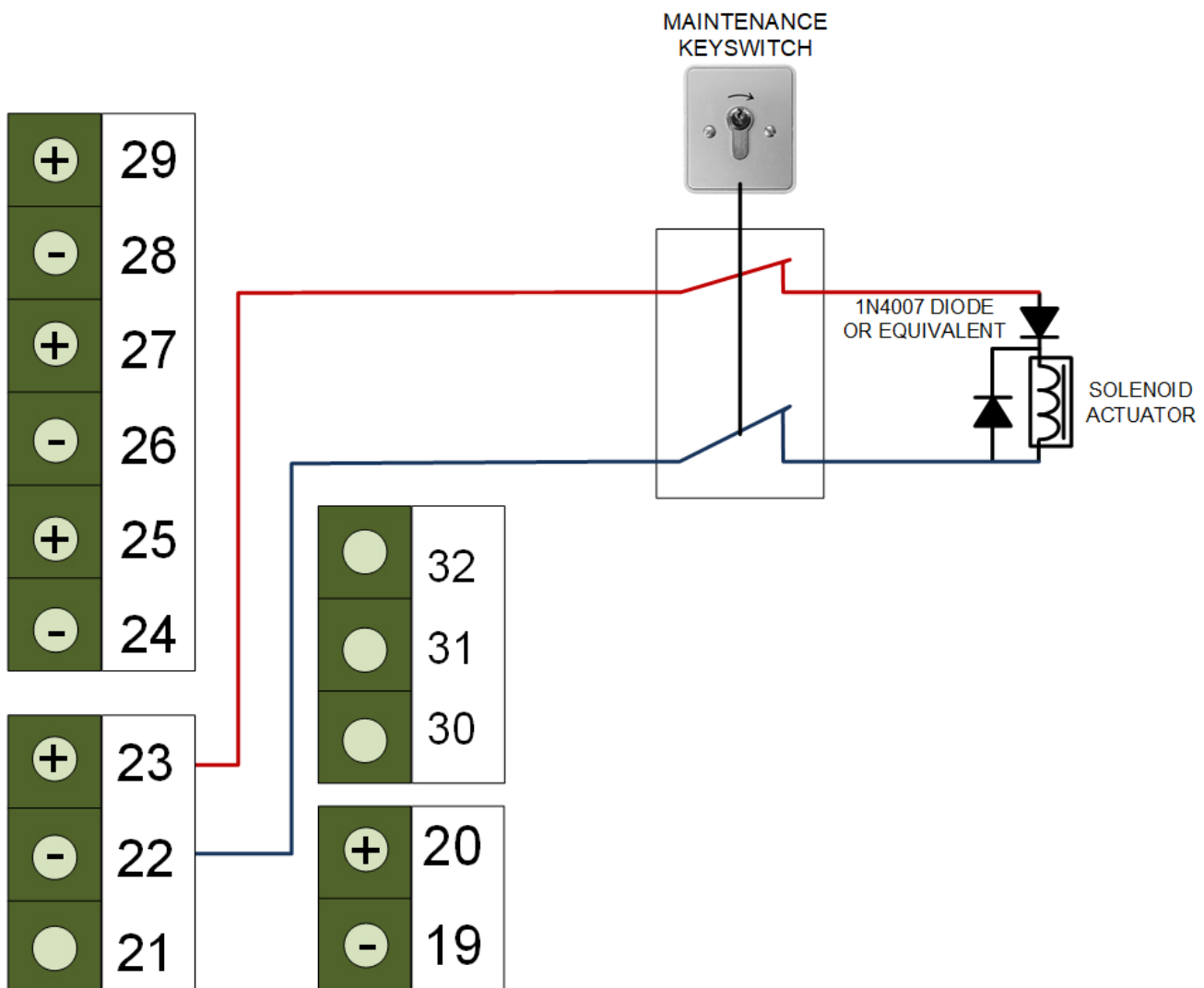

22 WIRING & CABLE SPECIFICATIONS:

- There is NO need for shielded cable
- Use a pair twisted cable, this strength the protection against electrical or magnetic field.
- Minimal solid copper core diameter, extinguisher line cable <50 meters length 1,0 mm² (AWG 18)
- Minimal solid copper core diameter, extinguisher line cable >50 meters length 1,5 mm² (AWG 16)
- Minimal solid copper core diameter, fire detection cables 0,5mm² (AWG 20)
- Maximum solid copper core diameter other cables 1,0mm² (AWG 18)
- Maximum conductor resistance of the extinguishers cable is 24 Ω/km.
- Maximum cable length of the fire zone cables is 50 meters.
- Maximum cable length of the cable from NANO to ETB is 30 meters.
- The total cable length of all extinguishers together is max 100 meters in total.

23 TECHNICAL SPECIFICATION

Environment

Ambient Temperature Range	-25 to +55 degrees Celsius
Dust and water rating	IP65
Compass safe distance	minimum 50 mm

Power related specification

Input voltage main and emergency battery	12/24 VDC +/-30%
Maximum power usage	1 Watt quiescent 5 Watt in alarm
Maximum contact rate relays	30 VDC/1A
Voltage fire zone	15 Vdc
Limited alarm current fire detectors	60 mA
Sounder / beacon voltage main powered mode	12 – 22 VDC
Sounder / beacon alarm maximum current	150 mA

Connector and cable specification

Conductor cross section solid (Cross Sectional Area mm ²)	0.5 mm ² ... 1.5 mm ²
Conductor cross section flexible (Cross Sectional Area mm ²)	0.5 mm ² ... 1.5 mm ²
Conductor cross section AWG	20 ... 16
Stripping length	8 mm

Aerosol extinguisher output specification

Max extinguisher count ETB/L (Igniter ≤ 2ohm)	8 connected on ETB max 100-meter cable
Max extinguisher count ETB/H (Igniter ≥ 2ohm)	6 connected on ETB/H max 100-meter cable
Max extinguishers count without ETB	6 connected without ETB max 100-meter cable
Extinguisher release current	1,3A
Extinguisher release pulse length	35 ms

Solenoid extinguisher output specification

End of line component	2 x back - EMF diodes 1N4004 or equal
Maximum number solenoids	1
Maximum coil resistance	25 to 200 ohms
Maximum current	1 A
Voltage	24Vdc
Extinguisher release pulse length	20 seconds

Detection zone, hold and extinguishing release inputs

Normal state	> 8 kΩ < 12 kΩ
Alarm load	< 100 Ω >1.2 kΩ
Zone fault threshold 1	< 100 Ω
Zone fault threshold 2	> 1.2 kΩ < 8 kΩ
Zone fault threshold 3	> 12 kΩ
Alarm resistant	470 Ω
End of line resistant	10 kΩ

24 DEVICES SUPPORTED AND INVOLVED BY THE NANO APPROVAL

24.1 DETECTION DEVICE SUPPORT

The detector types below have been evaluated on the NANO and are approved for such		
Part no	Type	Brand
ORB-OP-42001-MAR ¹	smoke detector	Apollo
ORB-OH-43001-MAR ¹	smoke/heat detector	Apollo
ORB-HT-41002-MAR ¹	heat 61°C detector	Apollo
ORB-HT-41004-MAR ¹	heat 73°C detector	Apollo
ORB-HT-41006-MAR ¹	heat 90°C detector	Apollo
ORB-MB-00001-MAR	standard detector base	Apollo

24.2 SOUNDER/BEACON DEVICE SUPPORT

Part no	Type	Brand
YL40/DL/C/25/WN/WR	sounder beacon	Clifford Snell
VTB-32EM-DB-RB/RL (VTB ²)	Sounder beacon	Cranford

Note: 1 Device input voltage 8 – 22 VDC

Note: 2 Device input voltage 18 – 22 VDC

Always check the specification of the devices of your preference before installing them on the NANO control panel.

25 ENCLOSURE SPECIFICATIONS

- outside enclosure : 120 x 80 x 58,5 mm w x h x d
- protection class : IP 65
- color of enclosure : black RAL 9005
- enclosure material : ABS suitable for outdoor use
- cable gland holes : 7 predrilled holes

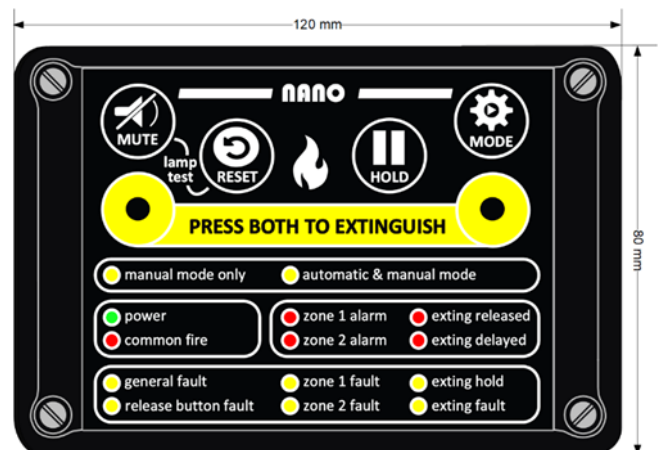
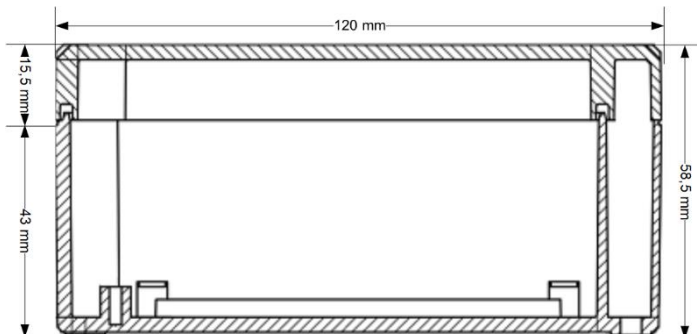

26 NANO FIRE DETECTOR AND WIRING OPTIONS

There are three options for connecting fire detectors to the NANO.

- Conventional Apollo Orbis Marine and Fireclass fire detectors
- Heat detectors
- Linear cable heat detection

26.1 APOLLO DETECTOR

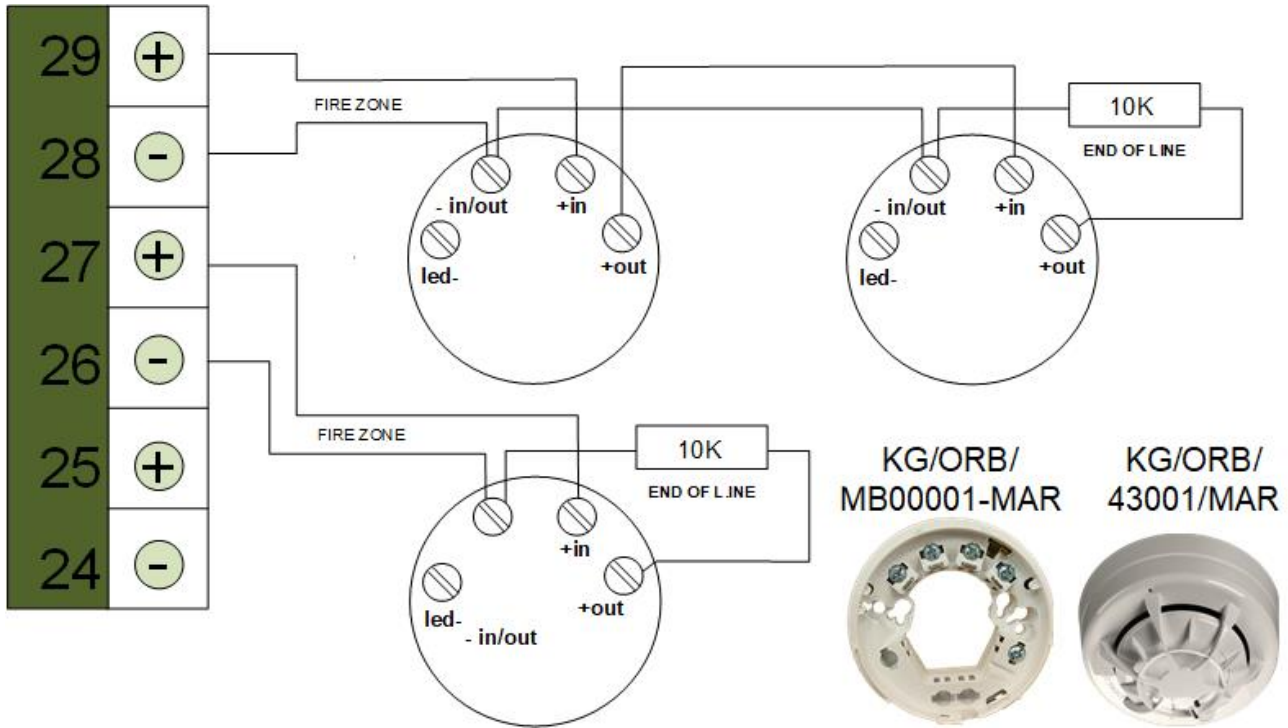

26.2 FIRECLASS DETECTOR

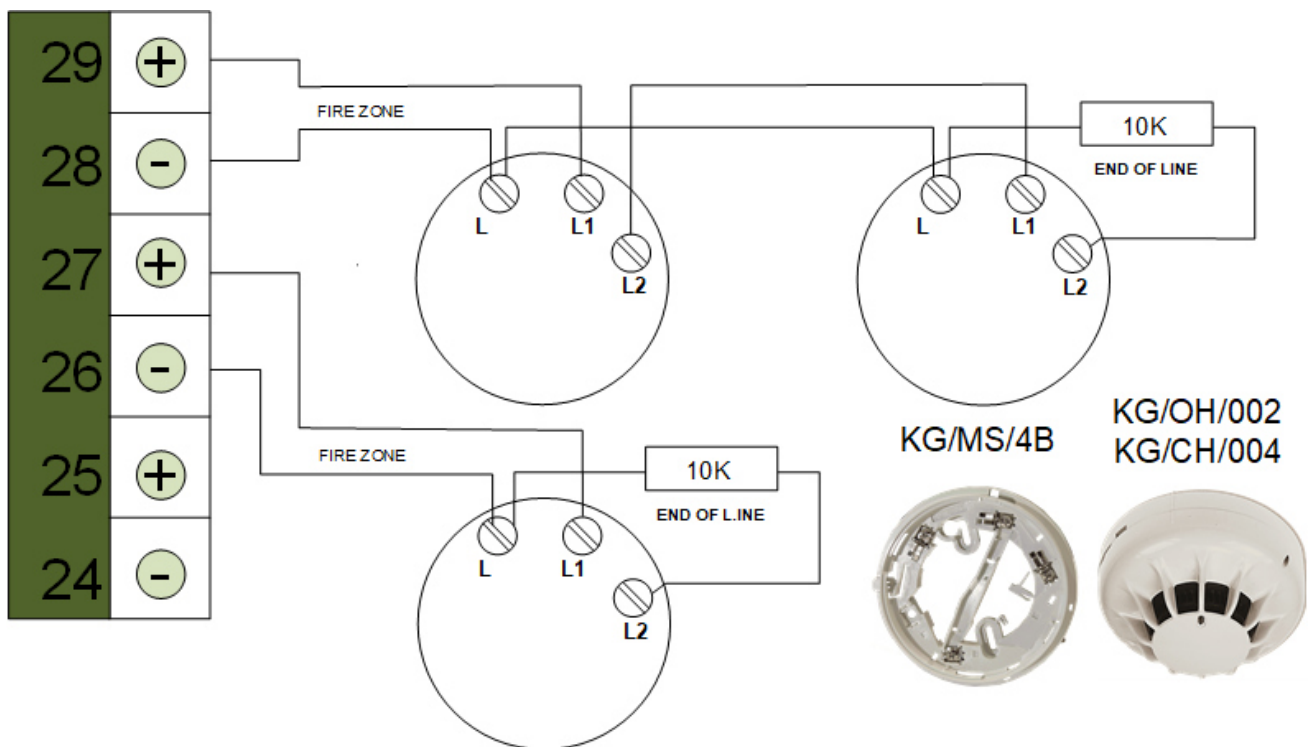

27 NANO LINEAR CABLE HEAT DETECTION

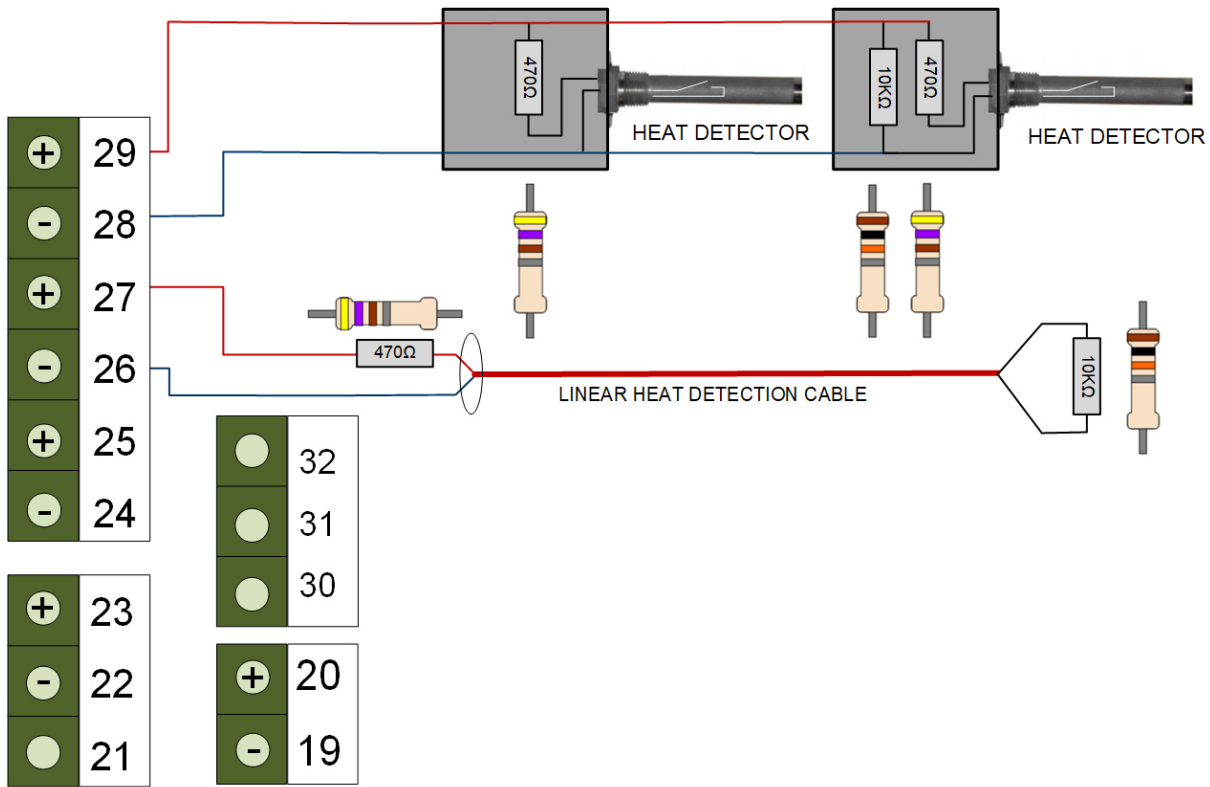

28 NANO EXTERNAL EXTINGUISHERS RELEASE & HOLD WIRING OPTIONS

The NANO has a separate input for external extinguishing release and external hold-off button.

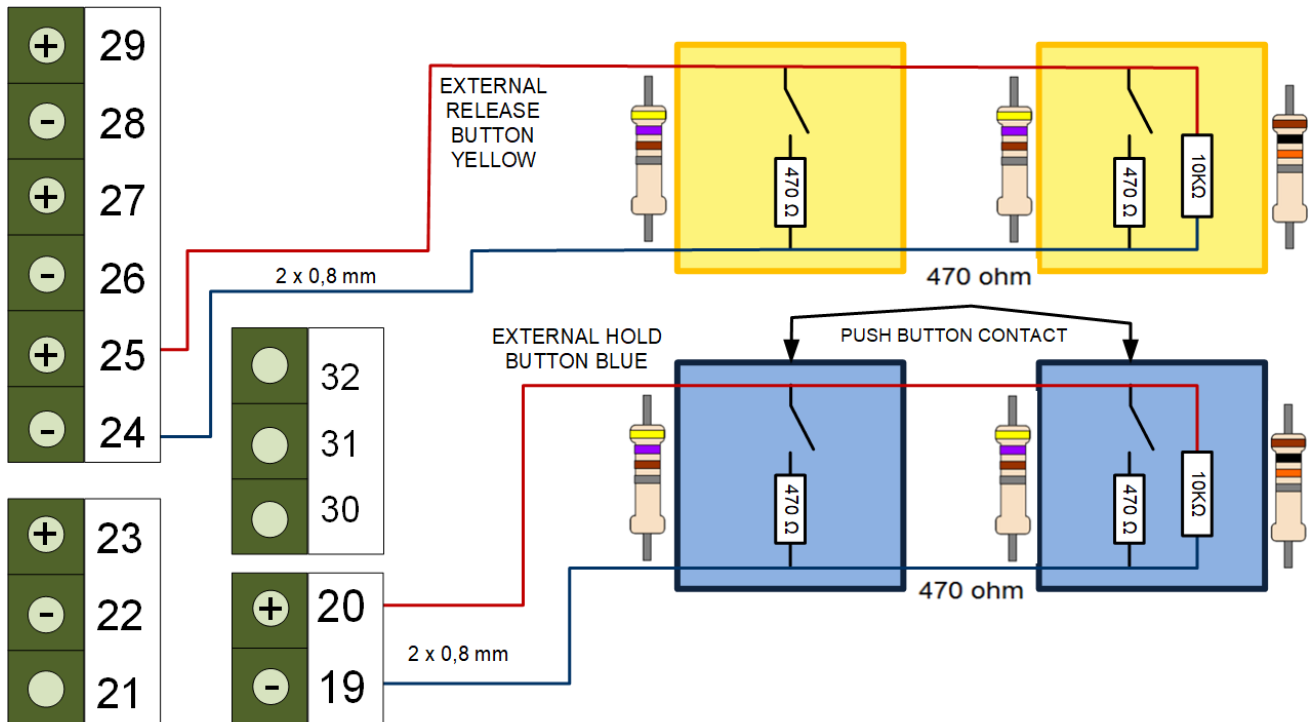

29 YL 40 WIRING OPTION SOUNDER & BEACON

By a single sounder beacon follow the connection diagram below. The recommended setting gives the best and deviating alarm signal compared to the usual evacuation alarm signal on vessels.

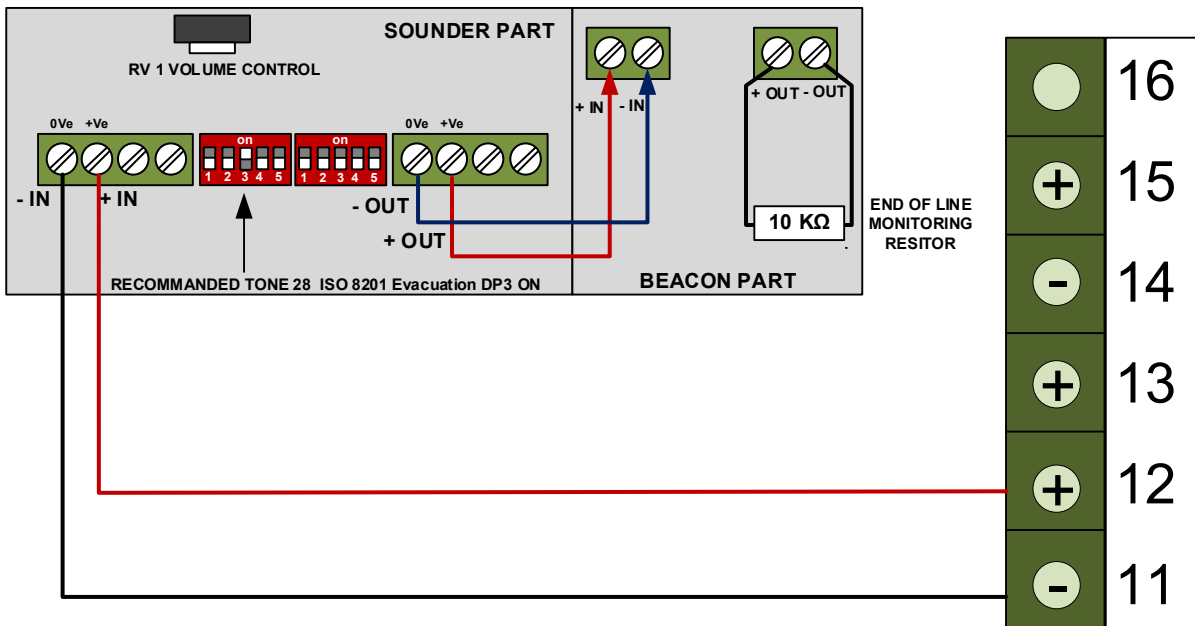

30 VTB-EM WIRING OPTION SOUNDER & BEACON

By a single sounder beacon follow the connection diagram below. The recommended setting gives the best and deviating alarm signal compared to the usual evacuation alarm signal on vessels.

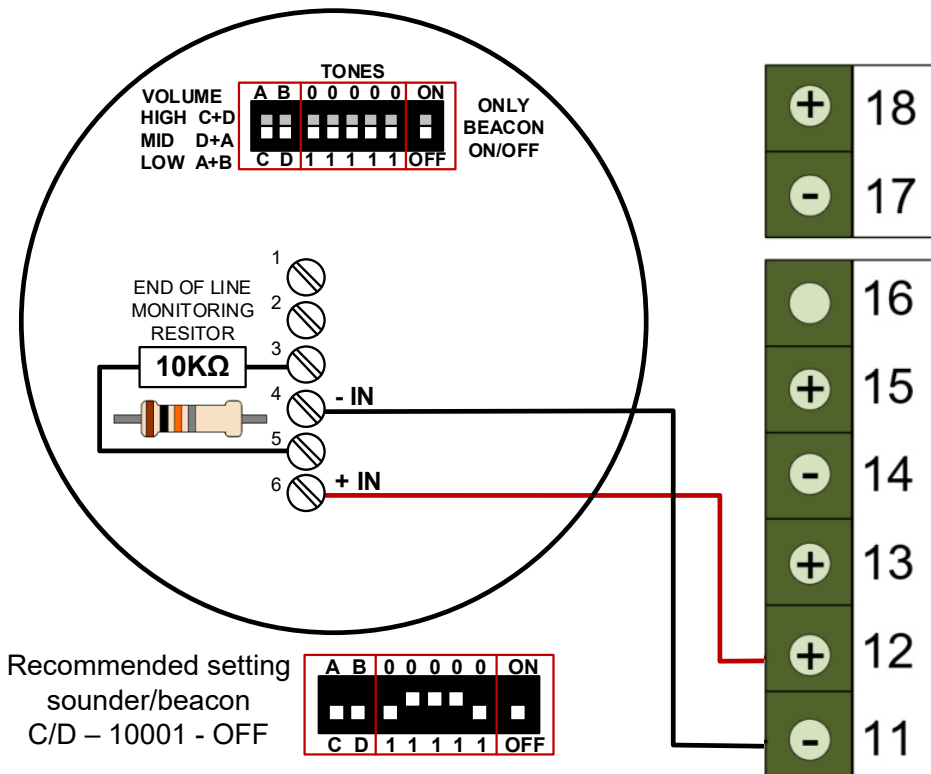

31 YL 40 WIRING OPTION EXTENDED SOUNDER & BEACONS

In some cases, the installation of a second signaling device is necessary. Usually this is caused by the lack of visibility of the optical alarm beacon in the protected area. In a noisy environ, the optical alarm signal is the leading warning element. By more than a single sounder beacon follow the connection diagram below. The recommended setting gives the best and deviating alarm signal compared to the usual evacuation alarm signal on vessels. At some sounders the end of line resistor is not necessary, because the resistance of the sounder input is sufficient to monitor on short circuit and/or wire break.

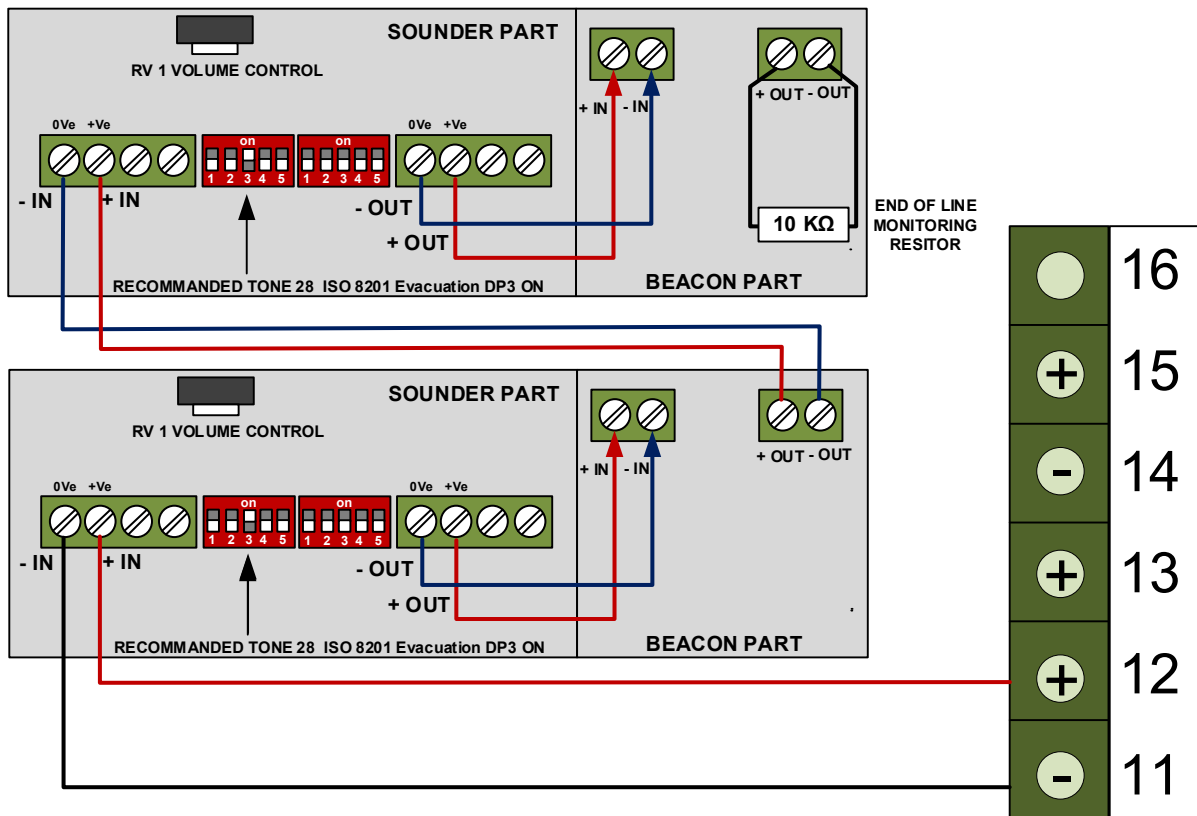

32 VTB-EM WIRING OPTION EXTENDED SOUNDER & BEACONS

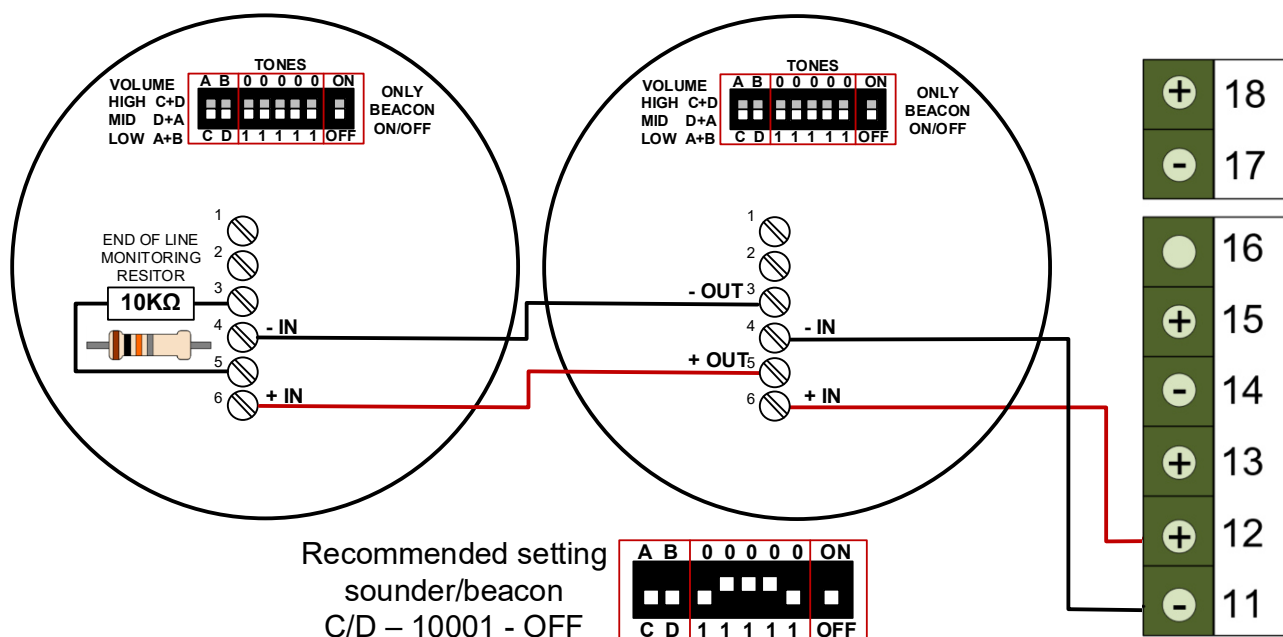

33 NANO WITH ETB CONNECTION

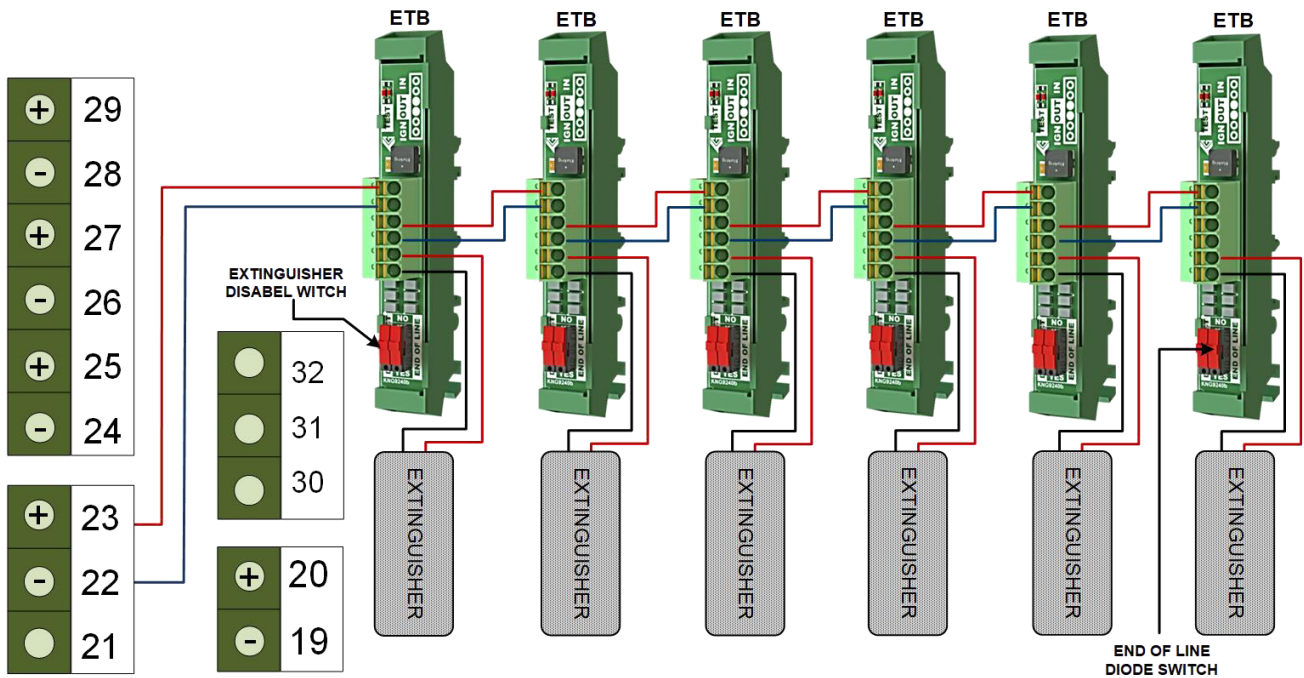

34 NANO WITHOUT ETB CONNECTION

A connection as shown below with a junction box is technically possible. However, it is **not** covered by the manufacturer's warranty. The manufacturer only guarantees the proper functioning of the NANO in combination with an ETB. Only an ETB has a bridge protection against a possible early blockage, which always ensures that the activation current flows through all igniters.

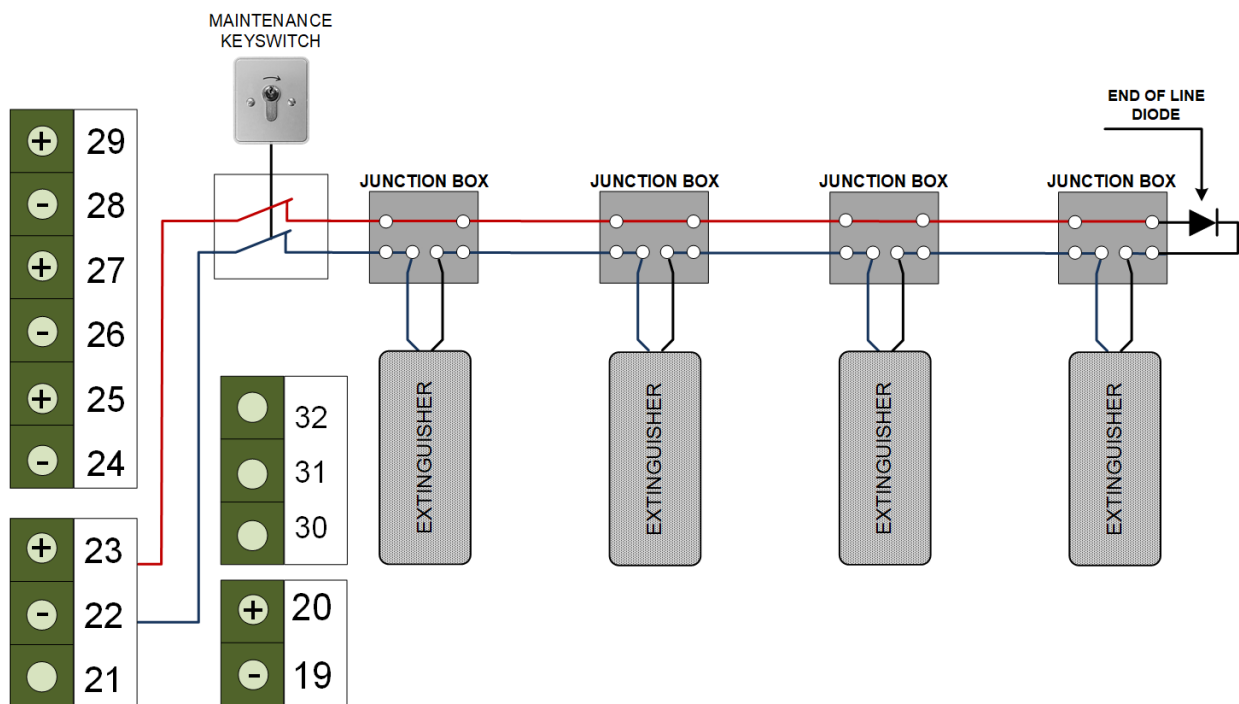

The diagrams of operating principles of the NANO fire-/extinguisher system, included in this manual, are intended to support this manual and are therefore not intended and suitable for technical implementation or realization. No part of this manual may be reproduced, stored in an automated database, or made public in any form or by any means either electronically, mechanically or by photocopying, recording, or in any other way, without prior written permission from K&G Groep B.V. The policy of the K&G Groep B.V. is one of continuous improvement and as such we reserve the right to amend product specifications at any time and without prior notice. Errors and omissions excepted.

Outdated or replaced computers and electronics are valuable sources for secondary raw materials, if recycled. Dealers of the NANO system must comply with local regulations for waste separation applicable in the country where the supplier is located. Questions concerning the information presented in this manual may be addressed to your dealer. For technical questions or support contact your dealer or further assistance.

