

Design Installation Operation Manual



NANO MARINE

FIRE DETECTION EXTINGUISHING CONTROL SYSTEM



TABLE OF CONTENTS

1	DOCUMENT REVISION DETAILS	3
2	SOFTWARE UPGRADE DETAILS	3
3	IMPORTANT NOTES	3
4	INTRODUCTION	3
5	CERTIFICATION	4
6	ENCLOSURE & INSTALLATION	4
7	MAINTENANCE & CLEANING	4
8	NANO MARINE SYSTEM	5
9	ALTERNATIVE OPTION.	6
10	KEY PROPERTIES	7
11	FEATURES NANO/MAR/SYSTEM	7
	11.1 ACOUSTIC ALARM	7
	11.2 EXTINGUISHANT RELEASE OUTPUT	7
	11.3 HISTORIC EVENT LOG	8
	11.4 COMMUNICATION PORT	8
	11.5 DIRECT RELEASE	8
	11.6 VEHICLE MODE (NORMALLY NOT IN USE IN MARINE APPLICATIONS)	8
	11.7 GENERAL FAULT RELAY	8
	11.8 VOLT FREE CONTACT FIRE RELAY IN SINGLE OF DUAL MODE	9
	11.9 SINGLE OR DUAL ZONE	9
	11.10 EXTINGUISHANT RELEASE DELAY	9
12	INPUTS	9
	12.1 DETECTION ZONES	9
	12.2 EXTERNAL RELEASE INPUT	10
	12.3 EXTERNAL HOLD INPUT	10
13	OUTPUTS	10
	13.1 VOLT FREE CONTACT RELAY OUTPUTS	10
	13.2 MONITORED EXTINGUISHING OUTPUT	10
	13.3 MONITORED SOUNDER OUTPUT	10
14	CONTROL BUTTONS	11
	14.1 MUTE	11
	14.2 RESET	11
	14.3 LAMP TEST	
	11	
	14.4 HOLD EXTINGUISHING RELEASE	11
	14.5 AUTOMATIC & MANUAL RELEASE OR MANUAL ONLY MODE	11
	14.6 EXTINGUISHING RELEASE	11
15	LED INDICATORS	12
	15.1 MANUAL RELEASE ONLY	12
	15.2 AUTOMATIC & MANUAL RELEASE	12
	15.3 POWER (PSU 1 IS MAINS PSU 2 IS BACKUP)	12
	15.4 COMMON FIRE	12
	15.5 FIRE ZONE ALARM	13
	15.6 EXTINGUISHING RELEASED	13
	15.7 EXTINGUISHING DELAY	13
	15.8 GENERAL FAULT	13
	15.9 FIRE ZONE FAULT	13
	15.10 EXTINGUISHING RELEASE HOLD	13
	15.11 EXTINGUISHING RELEASE FAULT	13
	15.12 INTERNAL FAULT INDICATORS	13
16	DIP SWITCHES	14
	16.1 SETTINGS	14
	16.2 DIRECT RELEASE (DIP SWITCH 1)	14
	16.3 VEHICLE MODE (DIP SWITCH 2)	14
	16.4 EXTINGUISHING RELEASE OUTPUT (DIP SWITCH 3)	14
	16.5 SINGLE OR DUAL FIRE ALARM (DIP SWITCH 4)	15
	16.6 VOLT FREE CONTACT RELAY (DIP SWITCH 5)	15
	16.7 EXTINGUISHING DELAY TIMER (DIP SWITCH 6-7-8)	15
17	WIRING THE NANO CONTROL PANEL AND NANO EXTINGUISHERS	16
18	WIRING DIAGRAM NANO EXTINGUISHERS TERMINAL BOX 10	17
19	CONNECTING USING THE EXTINGUISHER TERMINAL BOX	18
20	EXAMPLE SWITCH POSITION NANO EXTINGUISHERS TERMINAL BOX 10 WITH 7 EXTINGUISHERS	18
21	THE NANO MAR SYSTEM USING A SOLENOID ACTIVATOR	19
	21.1 WIRING A SOLENOID ACTIVATION SYSTEM	20
22	WIRING & CABLE SPECIFICATIONS:	20
23	TECHNICAL SPECIFICATION	21
24	DEVICES RECOMMENDED AND SUPPORTED BY THE NANO SYSTEM	22
	24.1 DETECTION DEVICE SUPPORT	22
	24.2 SOUNDER / BEACON DEVICE SUPPORT	22
25	ENCLOSURE SPECIFICATIONS NANO CONTROL PANEL	22
26	NANO MAR SYSTEM FIRE DETECTOR AND WIRING OPTIONS	23
27	EXTERNAL EXTINGUISHERS RELEASE & HOLD WIRING OPTIONS	24
28	YL 40 WIRING OPTION SOUNDER & BEACON	25
29	VTB-EM WIRING OPTION SOUNDER & BEACON	25
30	YL 40 WIRING OPTION EXTENDED SOUNDER & BEACONS	26
31	VTB-EM WIRING OPTION EXTENDED SOUNDER & BEACONS	26
32	WARRANTY	27
33	NOTES	27



1 DOCUMENT REVISION DETAILS

Issue	Modification Detail	Author	Date
01	1 st publishing document	CvT	01 / 09 / 2022
02	DNV approval received	CvT	22 / 12 / 2022
03	Textual improvement pt 10	CvT	01 / 02 / 2023
04	Improvement diagram 17-18-19	CvT	09 / 02 / 2023
05	Textual adjustment Modbus paragraph	CvT	19 / 03 / 2024

2 SOFTWARE UPGRADE DETAILS

Ver.	Modification Detail	Author	Date
02	1 st release Kiwa/Dare EMC test	CvT	01 / 08 / 2022
03	Event log extend	CvT	01 / 10 / 2022
2.0	Modbus register extension	CvT	19 / 03 / 2024

3 IMPORTANT NOTES

This manual should be thoroughly read and understood before installation and/or commissioning of the system is undertaken. The NANO MAR SYSTEM is not to be regarded as properly used when it is used without regard to any relevant information or advice relating to its use that has been made available by the supplier. The NANO MAR SYSTEM and the associated connections must be installed, commissioned, and maintained by a skilled, knowledgeable, and competent person or organization that is qualified to perform this work and is familiar with the objective of the equipment and the associated technical terminology. This equipment is not guaranteed unless the complete installation is installed and commissioned in accordance with the laid down local and/or national standards.

4 INTRODUCTION

The purpose of this document is to describe installation, service and troubleshooting of the NANO MAR SYSTEM. Please note that only aspects regarding the NANO MAR SYSTEM itself are covered by this manual. Physical placement of aerosol generators and cables etc. is not handled as these issues are typically to be specified specifically for each installation. The purpose of the NANO MAR SYSTEM is to control and monitor aerosol generators installed on a vessel part of a fire extinguishing system. The NANO MAR SYSTEM is a compact and robust stand-alone fire detection-extinguishant release system designed to protect various applications like electrical cabinets, engine rooms in vessels, yachts and other small areas or equipment. The NANO MAR SYSTEM continuously senses its inputs and, in the event of a fire, gives the correct output to enable a product specific fire extinguishing. The NANO MAR SYSTEM has two fire detection zones, any, or all of which can contribute to the extinguishant release decision. In a marine application, it's NOT common for a fire suppression system to be released by automatic fire detector. By default, the NANO MAR SYSTEM is set to only manual release but can also be changed to automatic & manual release via push buttons on the NANO control panel. Commissioning and testing of the NANO MAR SYSTEM is described in the NANO Commissioning and installation Quick Guide.



5 CERTIFICATION

The NANO MAR SYSTEM has successfully passed CE and FCC, EMC testing according to EN 50130, EN 61000, EN 55016, 47 CFR15-ICES-003, ANSI 63.4, IEC60945-pt11 and a DNV marine type approval according the DNV Class Guideline 0339-2021, certificate TAA000037H. For that the NANO MAR SYSTEM has endured extensive environmental tests such as vibration, dry heat, damp heat and cold tests in accordance with the requirements of the DNV-CG 0339 standard.

6 ENCLOSURE & INSTALLATION

The NANO control panel should be mounted on a dry, flat surface, at eye height in a horizontal position so that the enclosure cannot be deformed. The NANO extinguishers terminal box should be installed in an accessible area. Take into consideration environmental factors such as high temperatures. The enclosure is provided of 7 predrilled holes for cable glands. To ensure IP rating the cables must be brought in using appropriate cable glands.



7 MAINTENANCE & CLEANING

Maintenance of the NANO MAR SYSTEM is described in the NANO Owners Manual. There are not user-replaceable parts in the NANO MAR SYSTEM. Take Electrostatic Discharge (ESD) precautions when opening the NANO control panel or extinguishers terminal box. Avoid direct contact with any of the components or connectors connected to the printed circuit board. Failure to follow accepted ESD handling practices could cause damage to the NANO MAR SYSTEM. Before starting the cleaning process, bring the system out of operation to prevent an unwanted fire extinguishing system release. The NANO control panel has an IP rate 65. The IP rating system uses a 2-digit system to define its protection rating for all products. The first digit represents protection against solids and the second against liquids. The six stands for totally dust tight, for the protection against dust and other particulate. The five stands for protection against low-pressure jets (6.3 mm) of directed water from any angle (limited ingress permitted with no harmful effects). This IP rate concerns the housing and is only and exclusively applying if the correct mounting method is used, and the correct glands are fitted and assembled. It is important to note that improper cleaning of the NANO control panel front can damage this panel inhibit their ability to sense fire and activate the fire extinguishers. To remove dust and contaminants, use nonalcoholic products which has been designed for that purpose.

DON'T USE HIGH PRESSURE WASHERS OR STEAM CLEANERS

It will certainly damage the front foil with the NANO CONTROL PANEL control buttons and indication LEDs.



8 NANO MARINE SYSTEM

In addition to the NANO intended for land-based installations, a NANO version is available with a DNV-CG Type Approval in accordance with the 0339 standard. This NANO MAR SYSTEM consists of two components. The basis is formed by the NANO control panel which is placed on the bridge or in its vicinity. Then there is an extinguisher terminal box. The NANO extinguishers terminal box must be placed outside, but in the immediate vicinity of the to protected room. The NANO extinguishers terminal box is suitable for connecting up to 10 extinguishers. For **more than 10 extinguishers**, refer to **Appendix B** describing the NANO master slave configuration. From the NANO extinguishers terminal box, a cable led to the KVB plug & play Stat-X extinguisher installed in the volume to protected. Similar to the front of the NANO control panel, the front of the NANO extinguishers terminal box features two double-acting buttons for extinguisher release. When a fire emerges, press both yellow extinguishing release pushbuttons, this will trigger an alarm on the NANO control panel. The fire extinguishers will be released, depending on the programming dip switch (time) settings. The cable connection between the NANO control panel and the fire extinguisher connection box is continuously scanned for faults, such as short circuits or cable breaks. From the NANO extinguishers terminal box, each cable to the fire extinguishers is individually and constantly monitored for fault or malfunction. **In a marine application, it is NOT common that a fire suppression system intended for room protection is released by an automatic fire detector.** However, the NANO MAR SYSTEM has two fire zones suitable for connecting Marine approved Apollo Orbis fire detectors. The system can be set up that fire alarms from these fire detectors, signaled on the NANO control panel, considered as informative only. They don't have effect on the extinguishing system, nor activate the extinguishing system. By default, the NANO is set to only manual release but can be changed to automatic & manual mode.

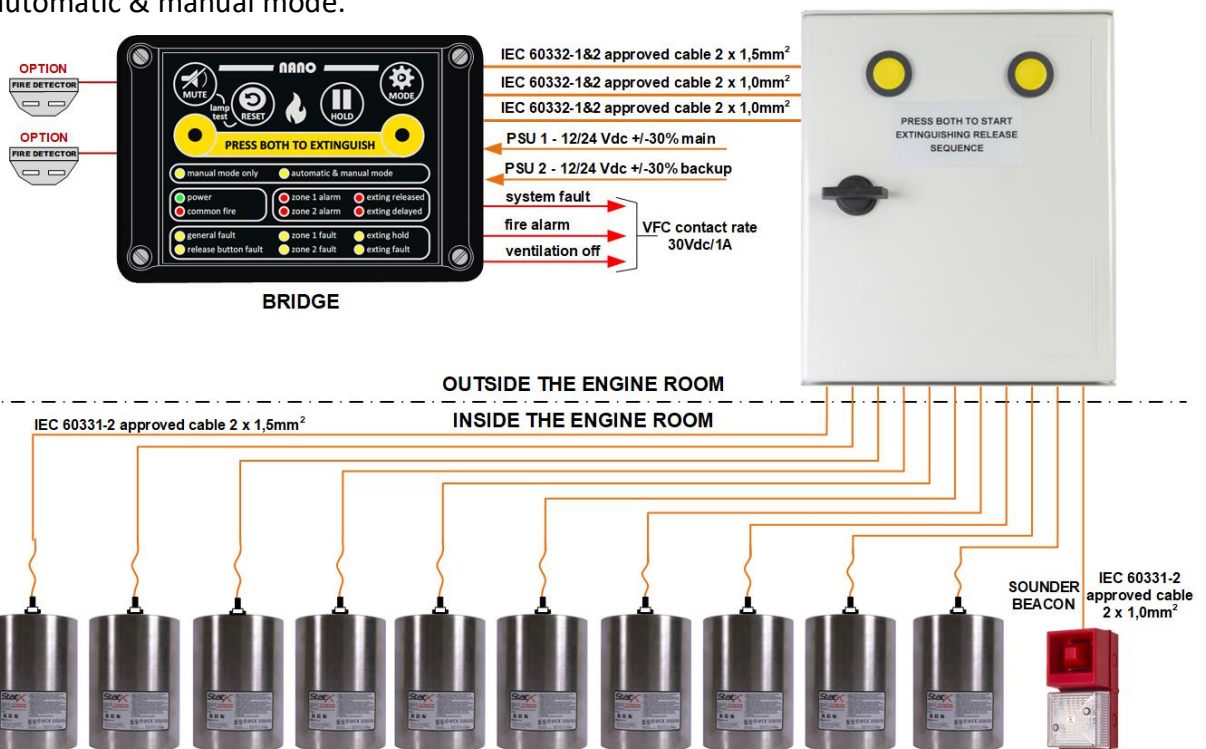
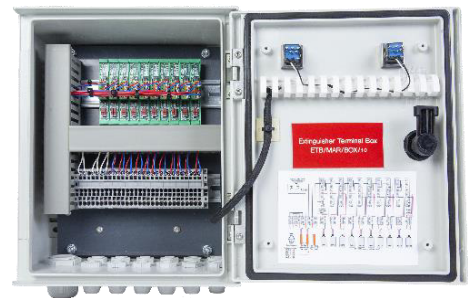

This is a scheme of working principles of the fire / extinguishing system, the scheme is intended to be supportive to the tender and therefore not intended and suitable for technical realization



9 ALTERNATIVE OPTION.

The total cable length of the system is 125 meters, which is the distance from the NANO control panel to the NANO extinguishers terminal box and the joint cable length from the NANO extinguishers terminal box to all extinguishers. if the distance exceeded the 125 meters, you have the option to install the NANO control panel in the immediate vicinity of the nano extinguishers terminal box and install on the bridge a yellow extinguishing release button, with transparent flap to avoid an unwanted release, to be able to realize a remote extinguishing release action from the bridge. the distance from the NANO control panel installed next to the NANO extinguishers terminal box to the yellow extinguisher release button on the bridge should not exceed 150 meters. the operation of extinguisher release buttons on the NANO extinguishers terminal box remains maintained. remove the 10kΩ resistor from the NANO extinguishers terminal box and place it in the yellow extinguishing release button on the bridge.

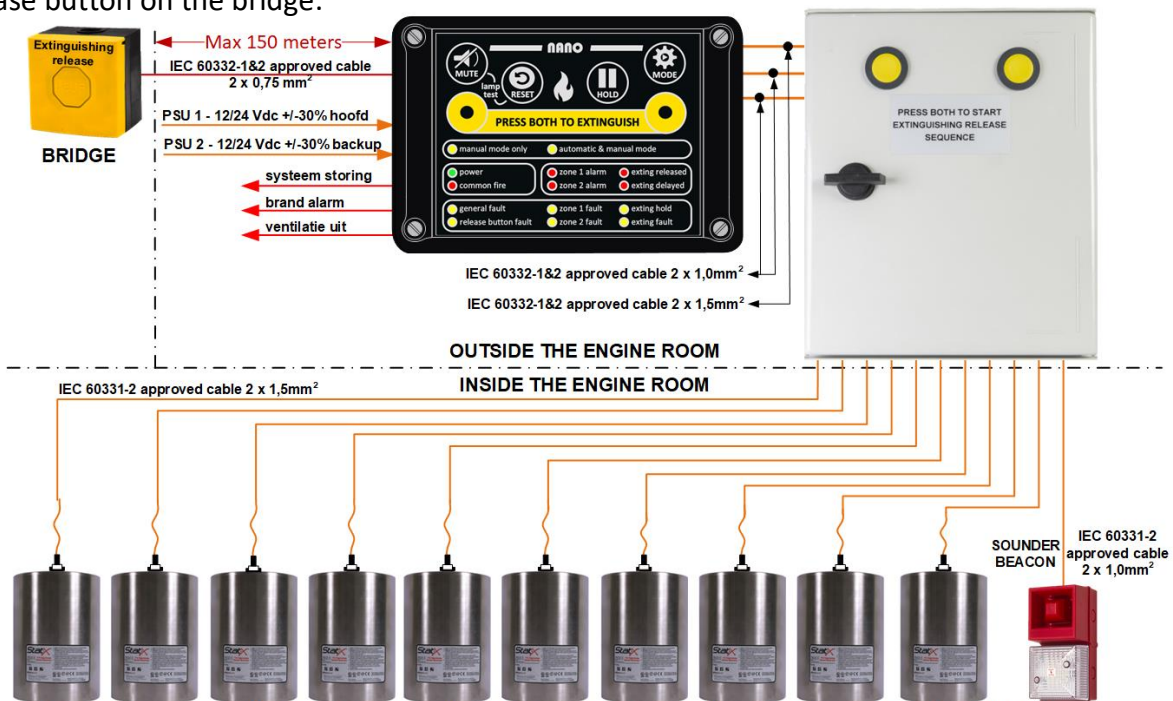

This is a scheme of working principles of the fire / extinguishing system, the scheme is intended to be supportive to the tender and therefore not intended and suitable for technical realization

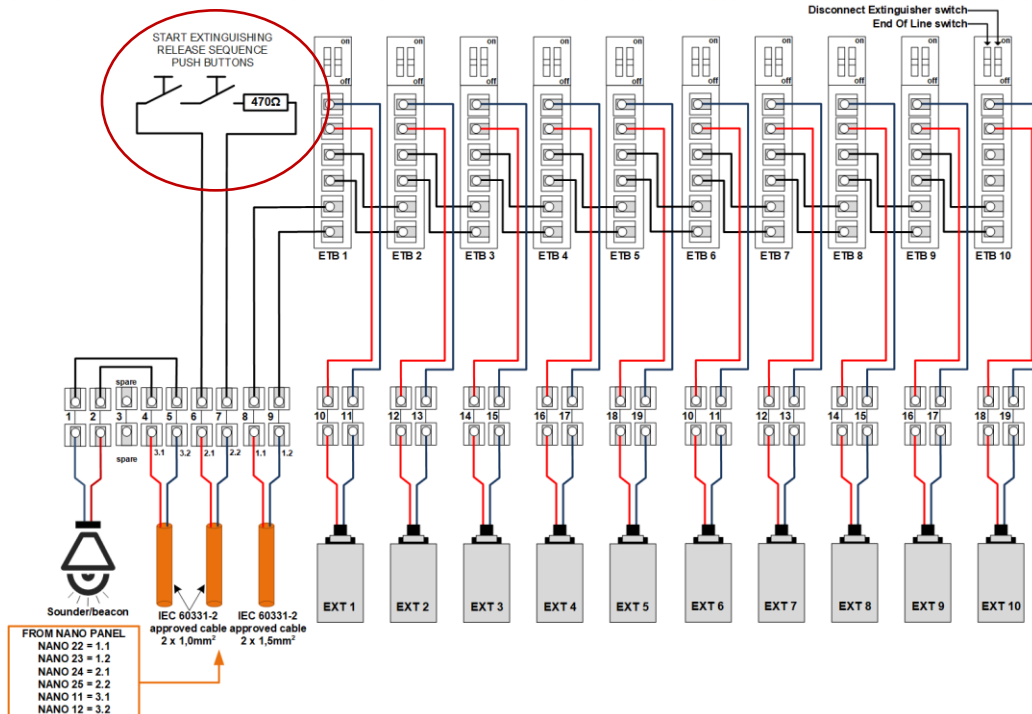

10 KEY PROPERTIES

- Able to set to manual, single stage or double stage detection, alarm, and extinguishing
- Outputs for fire, fault, ventilation off and visual & acoustic alarm device
- A full monitored output for the aerosol fire extinguishing generators
- Two full monitored fire alarm input groups (zones) for linear heat and / or point detectors
- Two full monitored alarm input groups for external extinguishing release and hold function
- Double extinguisher release buttons to prevent unwanted releases
- Extinguishers hold release button to postpone releases
- Extinguisher release delay to prevent unwanted releases
- Extinguishing delay which can be set between 0 and 35 seconds
- Additional option to override the release extinguishing delay after manual release
- Additional functionality regarding separated external hold-off functions
- Additional functionality regarding separated external release extinguishing functions
- Historic event log memory readable from a mini-USB port
- Modbus RS485 communication port
- The NANO MAR SYSTEM works on input voltage 12/24 Volt DC +/- 30%
- The NANO control panel has an IP 65 waterproof enclosure, with cable glands
- The NANO extinguishers terminal box 10 has an IP 65 waterproof enclosure, with cable glands.
- ESD and EMC protected, and CE and FCC marked.
- DNV-CG type approval; according the 0339 DNV-CG standard

11 FEATURES NANO/MAR/SYSTEM

11.1 ACOUSTIC ALARM

The NANO control panel has an internal attention signal. Malfunctions are standard signaled with a continuous tone signal, alarms with a pulsating tone signal. Deviating tone signaling takes place with extinguishing activation and operation of the hold (extinguishing delay) function. The voltage of the monitored output to drive an additional sounder/beacon is controlled by the NANO control panel and is independent of the main power supply voltage level.

11.2 EXTINGUISHANT RELEASE OUTPUT

The NANO MAR SYSTEM is equipped with two activation techniques for the activation of fire extinguishing systems. The selection can be made using programming dip switch 3. By default, the NANO control panel is programmed for the activation of electrical igniters intended for aerosol fire extinguisher generators, with programming dip switch 3 in the OFF position. The activation of aerosol fire extinguisher units is actuated by means of a current pulse of 1.3A for 50ms. When programming dip switch 3 is set to the ON position, the NANO MAR SYSTEM is suitable for activating an extinguishing system that makes use of a solenoid as actuator of the extinguishing installation. The activation voltage is then 24V DC with a maximum of 1A.

IMPORTANT

For the default current pulse activation method (Dip Switch 3 OFF) the NANO MAR SYSTEM supply voltage, meant for electrically activatable aerosol fire extinguisher units, is 8V to 28V DC. For the voltage-controlled activation (Dip Switch 3 ON), the NANO control panel supply voltage, meant for an extinguishing system that uses a solenoid actuator, is 24VDC.



11.3 HISTORIC EVENT LOG

The NANO control panel has an historic event log memory of 10,000 events readable from a USB port. Connect an USB cable between the Mini-B USB port and your computer. The device will act as an USB stick. Your operating system will create a new disk station. The files on the disk station are text files with logged events. The event log system is only meant for viewing, monitoring, and analyzing. The events are recorded without time and date but in order of event. Each time the NANO control panel reboots, a new file is created with a new batch number in the name. Pressed control buttons, detailed alarm and fault indications, and relay switching events are logged in the text files.



11.4 COMMUNICATION PORT

The NANO MAR SYSTEM has a Modbus network connection. Modbus enables communication among devices connected to the same network. A Modbus network consists of one master and several slave units, each with a unique address. For more information, see the MODBUS user manual. Also read Appendix B describing a NANO master slave configuration using the Modbus communication port.

11.5 DIRECT RELEASE

If the timer setting is set to a delay between 10 and 35 seconds, the direct extinguish programming dip switch 1 gives the choice to override the delay in case of a fire event. If a fire alarm is detected, and the NANO control panel starts the count-down timer, you can override the delay timer. By pressing the dual release extinguishing buttons on the front of the NANO control panel or the external release extinguishing button on the NANO extinguishers terminal box, the extinguishing releasing process starts without delay immediately. This function can be selected via programming dip switch 1.

11.6 VEHICLE MODE (NORMALLY NOT IN USE IN MARINE APPLICATIONS)

If the extinguishing system is intended for the protection of a vehicle engine bay, then a programmed extinguishing delay must be disabled, when the vehicle is parked. A fire extinguisher delay is then of no use and should be overridden. As soon as the ignition switch is used again, even for a very short moment, the system returns to the programmed state. In vehicle mode, a single or dual (depending on the dip switch position) fire alarm immediately releases the extinguishers without delay. In normal operation, the vehicle powers the NANO control panel at connection point terminal 15 + and 14 -, which means that the engine is switched on. In vehicle mode, the + on connection point 15 must be extended with a + on connection point 13. If the vehicle is parked and the driver removes the car key from the ignition lock, then this should remove the voltage at connection point 13 and thus eliminate any delay. When the vehicle function (programming dip switch 2) is enabled, the green power LED flashes at a different frequency than when switching to secondary voltage. When the vehicle mode is not in use and there is no external back-up battery/power supply available, connect battery inputs connection point 17 and connection point 18 in parallel on respectively the power connection point 14 and 15 to avoid a battery failure signal. This function can be selected via dip switch 2. Please note that the vehicle mode does not work in the only manual mode (12.5)

11.7 GENERAL FAULT RELAY

The fault relay is normally energized and will de-energize upon any fault condition including total loss of power. This secures a complete fail-safe condition of the NANO MAR SYSTEM in case of a fault condition.



11.8 VOLT FREE CONTACT FIRE RELAY IN SINGLE OR DUAL MODE

A single or dual fire indication triggers the VFC relay. In the single mode the VFC relay will be activated when one of the fire zones have a fire alarm condition. In the dual mode this relay shall be activated after both fire zones have a fire alarm condition. This function can be selected with dip switch 5.

11.9 SINGLE OR DUAL ZONE

Usually, the extinguishing system is activated in the so-called two group-dependent status (avoiding coincidence). Two fire conditions must be met before an extinguishing activation will be initiated. In some cases, a single mode status can be handy. In dual (standard) mode the extinguisher(s) shall be released after both detection zones will have a fire alarm condition and cause an internal pulsing alarm sound. The fire relay and extinguisher are activated according to the dip switch settings. In single mode the extinguisher(s) will be released when one detection zone is in fire alarm condition and cause an internal pulsing alarm sound. The fire relay and extinguisher are activated according to the dip switch settings. This function can be selected via dip switch 4.

11.10 EXTINGUISHANT RELEASE DELAY

Extinguishing delay is only useful in normally occupied spaces. For the delay timer settings, there are 3 dip switches. With dip switch 6,7 and 8 can be, in steps of 5 seconds, the delay time to be set between 0 and 35 seconds. The countdown timer is used to wait a certain amount of time before extinguisher/s are activated.

12 INPUTS

The NANO control panel is equipped with two detection zones and two external button inputs (Extinguishing Release & Hold). These inputs are continuously scanned for alarm or fault detection. All inputs are monitored and require a 10 k Ω end of line resistor, even if the input is not used. The button inputs must have a trigger resistor between 470 and 1000 Ω .

12.1 DETECTION ZONES

The NANO control panel is equipped with two fire detection zone inputs. The loop inputs are continuously scanned for fire or fault detection. The loops are set to the following values:

- RESISTANCE of less than 100 Ω : FAULT
- RESISTANCE of more than 100 Ω and less than 1,5 k Ω : FIRE
- RESISTANCE of more than 1,5 k Ω and less than 8 k Ω : FAULT
- RESISTANCE of more than 8 k Ω and less than 12 k Ω : NORMAL
- RESISTANCE of more than 12 k Ω : FAULT

When a low resistance (less than 450 Ω) linear heat cable is used, a 470 Ω resistor must be installed in series at the begin of the loop on one of the wires. Otherwise, the wires of the linear heat cable which will give a fault instead of a fire alarm. Contrary to the linear heat cable, when using a Fenwal or equal thermal heat detector, a resistor of 470 Ω must be placed in series with the alarm contact, an end of line resistor 10 k Ω in parallel over the alarm contact and 470 Ω resistor. The maximum number of detectors in one zone is 4. The voltage of all monitored detection inputs is controlled by the NANO control panel and is independent of the main power supply voltage. The NANO control panel alarm zones 1 and 2 operate in the quiescent state with a voltage of 15 VDC. Each input zone needs an end of line resistor of 10 k Ω , even if the fire zone is not used.



12.2 EXTERNAL RELEASE INPUT

The NANO control panel has a separate input for an external release extinguishing button. The external release extinguishing button has the same function as the dual release extinguishing buttons (fire buttons) on the front of the panel. By pressing the external release extinguishing button, the fire extinguisher(s) will be released. Depending on the dip switch (time) settings it is possible to delay the release. The delay time can be set from 0 to 35 seconds in steps of 5 seconds. These loop inputs are continuously scanned for alarm or fault conditions.

12.3 EXTERNAL HOLD INPUT

The NANO control panel has a separate input for an external hold-off button. The external hold-off button has the same function as the internal hold-off button. When an alarm is active and this button is pressed, the extinguisher release is delayed. When the button is released, the system will wait the configured delay time (see DIP switches). Release of the Hold input shall re-start the countdown release timer from maximum.

13 OUTPUTS

The NANO control panel is equipped with 5 outputs, two monitored and three potential free. The monitored outputs are continuously scanned for open and short circuit fault conditions. The potential free outputs have a contact load of 30 VDC /1A. The monitored outputs are for the extinguishing output (extinguishing release) and for the electronic sounder/beacon output.

13.1 VOLT FREE CONTACT RELAY OUTPUTS

Contact load relays 30 VDC 1A.

- **1 relay output general fire alarm.** The general fire relay will energize upon activation of a fire condition on any of the fire zones or by pressing of the in or external extinguishing release buttons.
- **1 relay output general fault message.** The general fault relay signals the presence of a fault in the NANO SYSTEM. In the event of a complete power failure, the general fault relay will be activated.
- **1 relay output at 1st or 2nd fire alarm.** VOLT FREE CONTACT relay output is programmable for 1st or 2nd fire alarm and intended, among other things, for switching off ventilation and/or air conditioning of the area to be protected. **Marine settings see page 13 subject 14.1.**

13.2 MONITORED EXTINGUISHING OUTPUT

The NANO control panel is equipped with a fire extinguisher output monitored for short circuit and wire breakage. In combination with the ETB (Extinguishers Terminal Board), the NANO control panel extinguishing output is protected against reverse polarity and equipped with surge protection. Without the use of an ETB, this extinguishing activation output is NOT protected against surge and reverse polarity. If the ETB is not used then an end of line diode is required (1N5400, 1N4007, RL201, SF21).

13.3 MONITORED SOUNDER OUTPUT

This output, intended for the optical or acoustical alarm device, is monitored for short circuit and wire break by placing a 10 KΩ end-of-line monitoring resistor on the + and – connection (4 and 6) of the alarm device such as on the VTB-32EM sounder see schedule sheet at 20.



14 CONTROL BUTTONS

The NANO control panel has a clear and orderly front panel with which the system status of the NANO MAR SYSTEM can be determined rapidly. The figure shows the controls and indications with text. The NANO control panel facia consists of a special foil with embedded the control buttons and LED indicators.

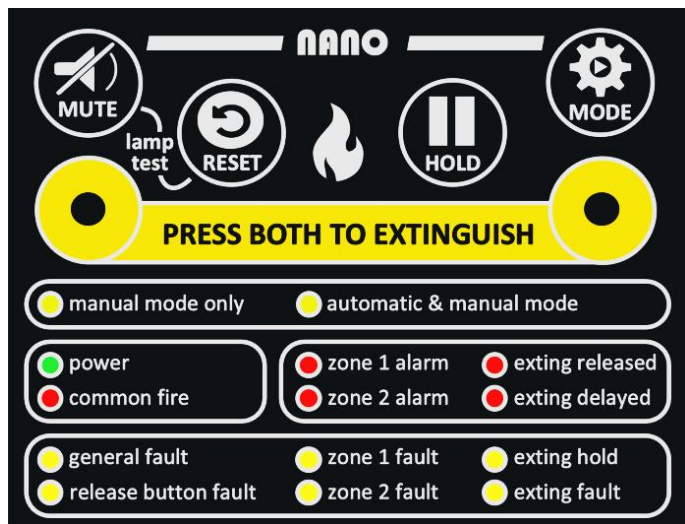

14.1 MUTE

The buzzer can be silenced at any time by pressing the Mute button. To silence the external sounder, press the Mute button twice.

In case of a second alarm the sounder and buzzer will be activated again.

14.2 RESET

After the cause of the alarm has been determined the NANO control panel can be reset by pressing the Reset button. Manual Call Points, if triggered, must first be reset locally. The NANO control panel will reset any latched devices. Fault indications are self resetting type and vanished automatically when the fault condition is removed.

14.3 LAMP TEST

All indicators and buzzer can be tested at any time by pressing the **Mute and Reset** simultaneously.

14.4 HOLD EXTINGUISHING RELEASE

By pressing the hold button at the panel or external hold button, as long this button is pressed, the extinguishing release sequence will be halted and cause the yellow hold activated indicator flash, and the buzzer to sound pulsating. When the control panel is in the second stage alarm condition and the hold function is activated, the extinguishing release sequence will be halted, the second stage sound shall change to first stage sound. Release the Hold button shall re-start the countdown release timer from maximum.

14.5 AUTOMATIC & MANUAL RELEASE OR MANUAL ONLY MODE

The mode of the system can be toggled between Manual Only and Automatic & Manual by operating the MODE push button on the NANO control panel. When the system is in Manual Only mode, the extinguishant cannot be released by the operation of automatic detectors. In that mode the automatic fire detectors are only informative. To switch the system from manual only tot automatic & manual press the MODE push button for 3 seconds. To return the system to manual mode only, press the MODE push button again for 3 seconds.

14.6 EXTINGUISHING RELEASE

When a fire emerges, press both front extinguishing release pushbuttons, this will trigger an alarm. The fire extinguishers will be released, depending on the programming dip switch (time) settings.



15 LED INDICATORS

The front of the NANO control panel has 1 common fire, 3 internal fault, and 13 individual LED indicators on the front divided in three sections to indicate general functions, fire alarm and the extinguishing status. Under normal state, control panel will have only the green, Power LED lite and either the Manual Only or Automatic and Manual LED lite. The yellow fault LEDs automatically turn off when the cause of the fault is recovered.



15.1 MANUAL RELEASE ONLY

When the yellow "manual mode only" LED lit, the extinguishing agent is not released by automatic fire detectors, but **only** by manual operation.

15.2 AUTOMATIC & MANUAL RELEASE

When the yellow LED "automatic and manual mode" is on, the extinguishing agent is released by the automatic fire detectors **and/or** manual operation.

15.3 POWER (PSU 1 IS MAINS PSU 2 IS BACKUP)

Under normal conditions the NANO control panel will have only the green, power on LED lit and either the manual only or automatic & manual LED lit. Failure of the mains power or disconnection of the backup power will cause a fault. The power LED lite differently, indicating an abnormality in the power supply to the NANO control panel. When starting the NANO MAR SYSTEM after a power failure or an extinguishers release, the green power LED flashes for maximal 1 minute until the system is ready and this LED lit continuously.

If the **mains** power supply is NOT present, the secondary power supply takes it over, the power LED flashes 1 x per second, the yellow general fault LED lit, the common fault relay will be deactivated.

If the **standby** power supply is NOT present, the power LED flashes 2 x per second followed by a pause of 1 second, then repeating, the general fault and internal battery fault LED lit, the common fault relay is deactivated.

If a **standby power source is not available**, then the connection points 17/18 must be connected to respectively point 14/15 to avoid a fault message.

When the **vehicle function (PROGRAMMING DIP SWITCH2)** is enabled, the green power LED flashes at a frequency of 90 flashes per minute when switching to secondary voltage.

15.4 COMMON FIRE

In the event of a fire alarm from either the fire alarm detectors or the operation of the extinguishant release pushbuttons, the red general fire LED lit.



15.5 FIRE ZONE ALARM

Upon receipt a fire alarm condition caused by the activation of a fire detector, the red alarm indicator of the relevant fire alarm zone will flash. The common fire indicator will always accompany this, and the internal buzzer sounds pulsating.

15.6 EXTINGUISHING RELEASED

The red extinguishing release indicator lights continuously when the extinguishers are activated. This red extinguishing release indicator lights up after ending of the configured extinguishing delay time, or when the two extinguishing release buttons on the front are pressed or the external release button is activated. A tone sounds when the extinguishing has released.

15.7 EXTINGUISHING DELAY

The red extinguishing delay indicator indicates that the extinguishing release delay is active. This indicator flash when the delay time is running. This indicator will light continuously when pressing the hold button. When the hold button is released, the indicator shall flash again and re-start the countdown release timer from maximum. This indicator turns off when the delay time has elapsed, and the extinguishing release has taken place.

15.8 GENERAL FAULT

General fault indicator lights and specific fault indicators flash. This yellow fault indicator will light continuously at any fault condition.

15.9 FIRE ZONE FAULT

When the NANO control panel has detected an error in one of the critical fire detection paths of the system, the specific yellow zone fault indicator flash and the general fault indicator lights up. The internal buzzer sounds pulsating.

15.10 EXTINGUISHING RELEASE HOLD

The yellow hold indicator flash and a different tone sounds as long the hold button on the panel front, or the external hold button is pressed. This yellow hold indicator is turns off when the hold button is released.

15.11 EXTINGUISHING RELEASE FAULT

This yellow indicator lights up continuously when a critical fault is detected (open or short circuit) in the extinguishing output line. This yellow indicator will turn off when the cause of this malfunction has been rectified.

15.12 INTERNAL FAULT INDICATORS

There are three extra yellow fault indicators on the internal electronic PCB, meant for second priority fault messages and these indicators will flash.

- LED 1 signals a fault in the monitored sounder/beacon line
- LED 2 signals a fault in the external extinguishing release hold input
- LED 3 signals a fault in the emergency power source PSU 2

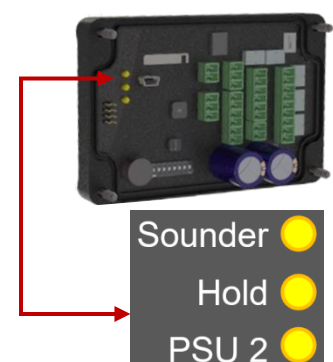

16 DIP SWITCHES

16.1 SETTINGS

Standard setting ex factory, all dip switches in the OFF position.

- Automatic fire detector as the initiators of an extinguishing action is the standard, no override the delay timer
- The vehicle mode is disabled
- Activation of electrical igniters for aerosol fire extinguishers
- Dual zone alarm for automatic extinguishing release.
- Volt Free Contact relay activates at 2nd fire alarm
- Extinguishant release delay 0 seconds

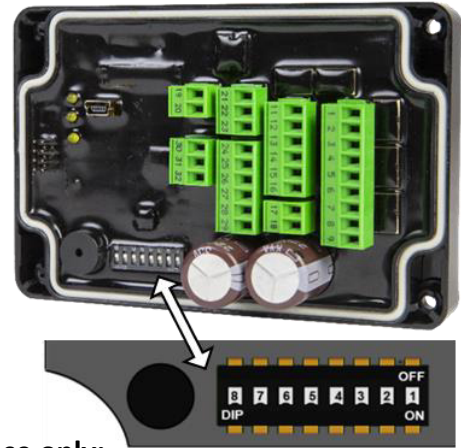

Recommended setting for marine application with manual release only:

- Front NANO control panel manual release ONLY, fire detectors are not in use (Dip Switch 1 OFF)
- The vehicle mode is disabled is not in use (Dip Switch 2 OFF)
- Activation of electrical igniters for aerosol fire extinguishers (Dip Switch 3 OFF)
- Dual zone alarm is not in use (Dip Switch 4 OFF)
- Volt Free Contact relay activates at 1st (Dip Switch 5 ON)
- Extinguishant release 20 seconds (Dip Switch 6 ON - Dip Switch 7 OFF – Dip Switch 8 OFF)

16.2 DIRECT RELEASE (DIP SWITCH 1)

If a fire alarm is detected, by the automatic fire detectors the countdown timer is started, you can override the timer when press the manual release. Dip Switch 1 OFF = extinguishing delayed also in manual operation if a delay has been programmed. Dip Switch 1 ON = extinguishing without delay in manual operation.

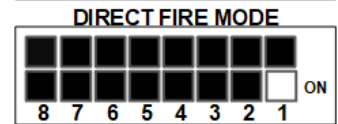
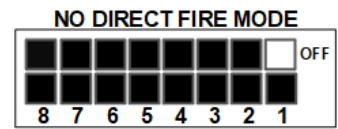

16.3 VEHICLE MODE (DIP SWITCH 2)

If the extinguishing system is intended to protect the engine compartment of a vehicle, a programmed extinguishing delay must be disabled when the vehicle is parked, and the driver leaves the vehicle. Dip Switch 2 OFF = system behaves as programmed with delay. Dip Switch 2 ON = delayed extinguishing is disabled when parked.

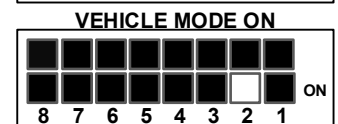
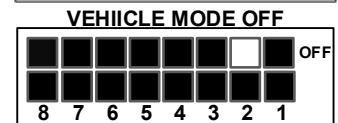

16.4 EXTINGUISHING RELEASE OUTPUT (DIP SWITCH 3)

The NANO system is equipped with two techniques for the activation of fire extinguishing systems. With dip switch 3 OFF the NANO control panel is programmed for the activation of electrical igniters intended for aerosol fire extinguisher units. When dip switch 3 is set to the ON position, the NANO system is suitable for activating an extinguishing system using a solenoid.

Dip Switch 3 OFF the system is suitable for electrical igniters of aerosol fire extinguishers 1,3A/50ms
Dip Switch 3 ON the system is suitable for solenoid activation 24V DC 1 A

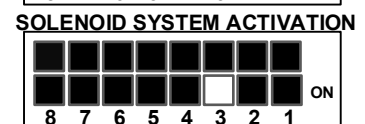
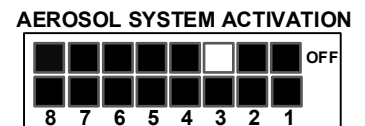

WARNING

When the Dip Switch 3 is in the ON position (solenoid only) DO NOT USE it in combination with a NANO extinguishers terminal box.

This may cause irreparably damage to the ETB's and the NANO control panel.



16.5 SINGLE OR DUAL FIRE ALARM (DIP SWITCH 4)

Normally we work in dual fire zone mode. In some cases, a single mode state can be useful. In dual mode, the extinguisher(s) are released after an alarm condition is detected in both fire zones. In single mode, the extinguisher(s) are released when one fire zone is in alarm.

Dip Switch 4 OFF = automatic extinguishment activation with 2 fire zones in alarm.

Dip Switch 4 ON = automatic extinguishing activation with 1 fire zone in alarm.

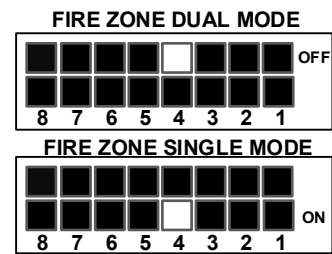

16.6 VOLT FREE CONTACT RELAY (DIP SWITCH 5)

Here one has a choice to have the relay active at the first fire alarm or after the second fire alarm.

Dip Switch 5 OFF = Volt Free Contact relay active with 2nd fire alarm.

Dip Switch 5 ON = Volt Free Contact relay active with 1st fire alarm.

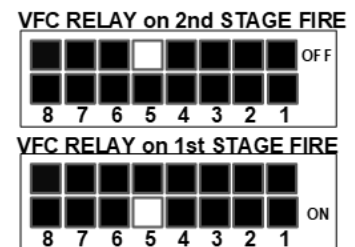

16.7 EXTINGUISHING DELAY TIMER (DIP SWITCH 6-7-8)

Extinguishing delay is only useful in normally occupied spaces. For the delay timer settings, there are 3 Dip Switches, which can be set between 0 and 35 seconds, with steps of 5 seconds. The count-down timer is used to wait a certain amount of time before extinguisher is activated. This timer can be set with the use of the timer Dip Switch 6,7 and 8.

- Dip Switch 6 OFF | I
- Dip Switch 7 OFF | I- is no delay
- Dip Switch 8 OFF | I
- Dip Switch 6 OFF | I
- Dip Switch 7 OFF | I- is 5 seconds delay
- Dip Switch 8 ON | I
- Dip Switch 6 OFF | I
- Dip Switch 7 ON | I- is 10 seconds delay
- Dip Switch 8 OFF | I
- Dip Switch 6 OFF | I
- Dip Switch 7 ON | I- is 15 seconds delay
- Dip Switch 8 ON | I
- Dip Switch 6 ON | I
- Dip Switch 7 OFF | I- is 20 seconds delay
- Dip Switch 8 OFF | I
- Dip Switch 6 ON | I
- Dip Switch 7 OFF | I- is 25 seconds delay
- Dip Switch 8 ON | I
- Dip Switch 6 ON | I
- Dip Switch 7 ON | I- is 30 seconds' delay
- Dip Switch 8 OFF | I
- Dip Switch 6 ON | I
- Dip Switch 7 ON | I- is 35 seconds delay
- Dip Switch 8 ON | I

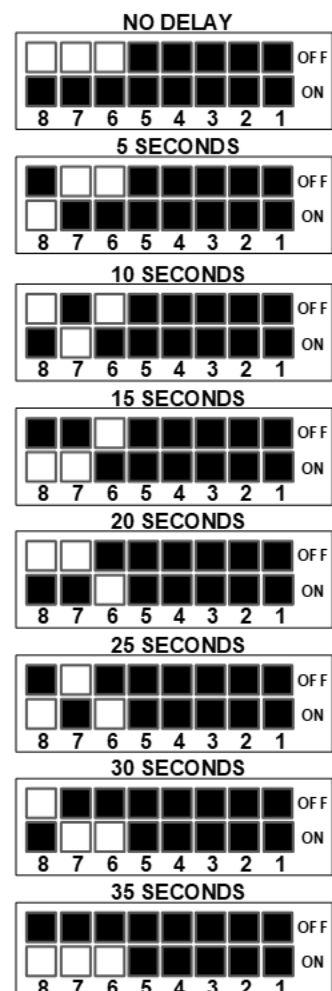

17 WIRING THE NANO CONTROL PANEL AND NANO EXTINGUISHERS

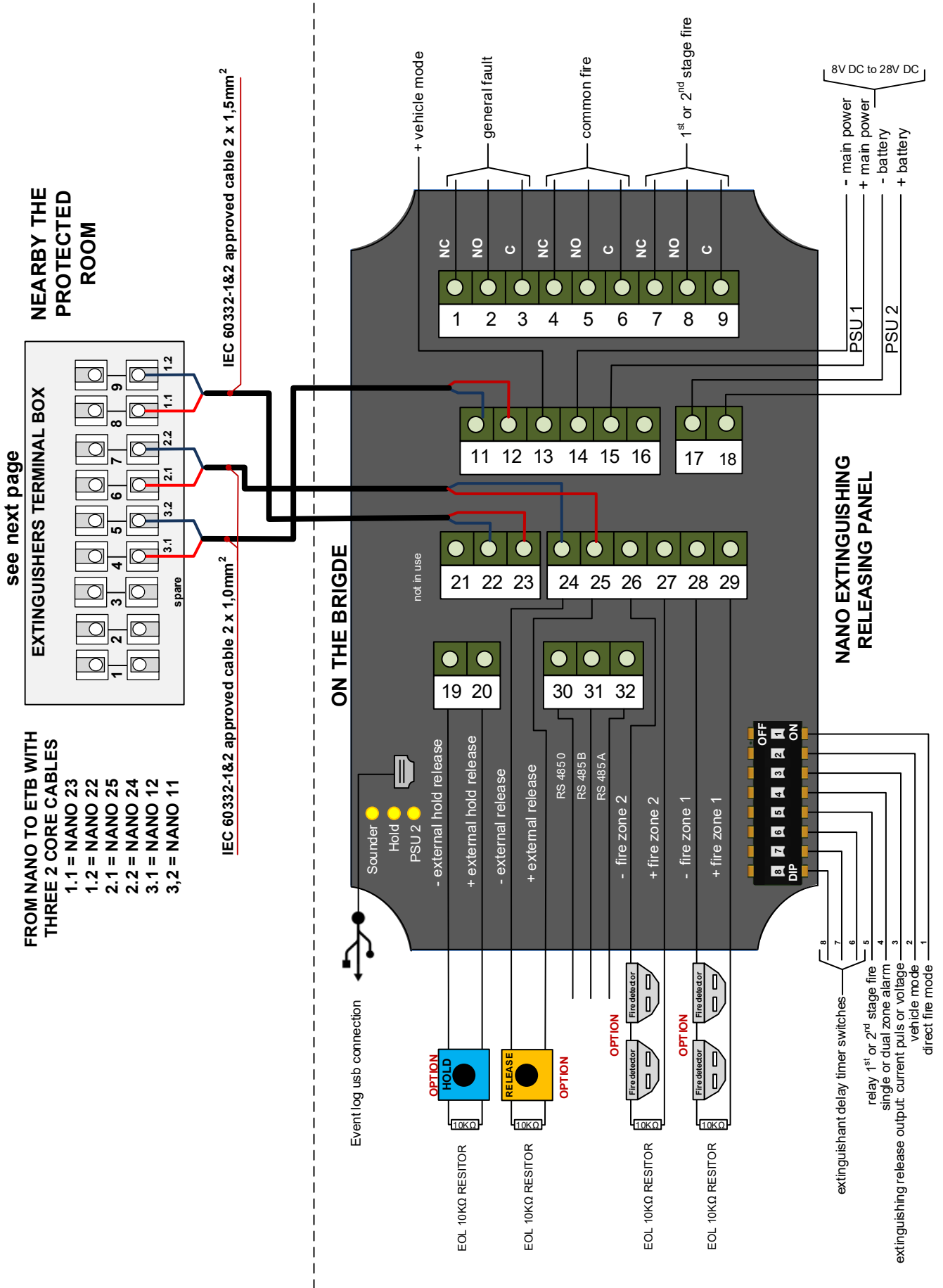

18 WIRING DIAGRAM NANO EXTINGUISHERS TERMINAL BOX 10

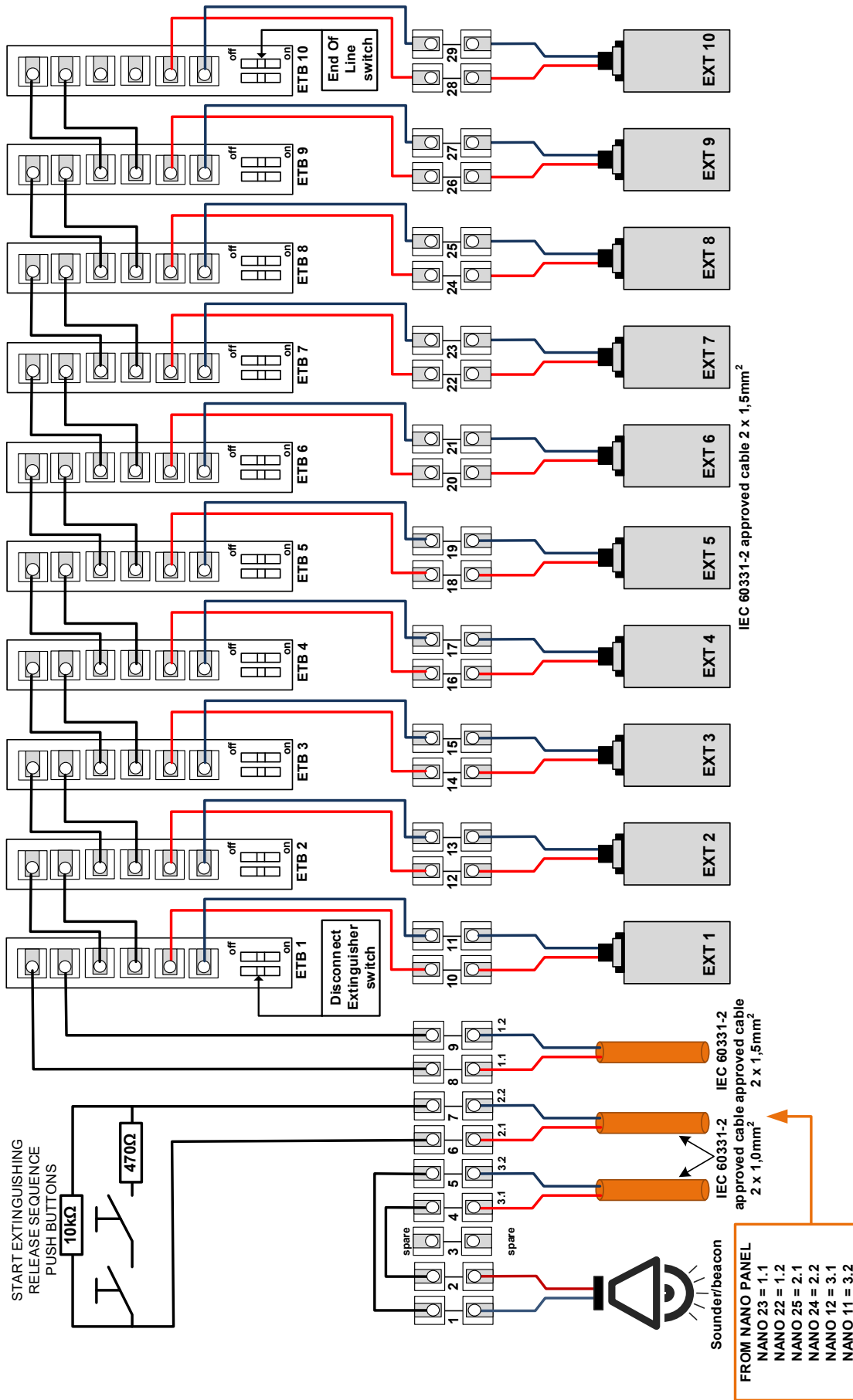

19 CONNECTING USING THE EXTINGUISHER TERMINAL BOX

The NANO extinguishers terminal box is developed for use with the NANO control panel and aerosol extinguishers. This terminal connection board is equipped with built-in security electronics, which ensures that all igniters of the extinguishing units are activated. Together with an end line switch, this option turns the NANO MAR SYSTEM into a complete and reliable fire detection and extinguishing system.

WARNING

Incorrect placement of the end line switch makes it possible to disable a part of the extinguisher’s activation circuit. Therefore, a visual inspection is an essential part of the commissioning and maintenance engineers’ work. This visual inspection must be a standard provision in the commissioning regulation.

DISCONNECT EXTINGUISHER

Move the disconnect switch in the YES position and the aerosol extinguisher is disabled and can not be activated. All ETB’s connected thereafter will remain in operation. A disablement will be signaled as fault on the NANO.

ENABLE END OF LINE DIODE

To monitor for short circuit or wire break, only the end of line switch on the last ETB must be set into the YES position. A failure to do so will be signaled as a fault on the NANO panel.

20 EXAMPLE DIP SWITCH POSITION NANO EXTINGUISHERS TERMINAL BOX 10 WITH 7 EXTINGUISHERS

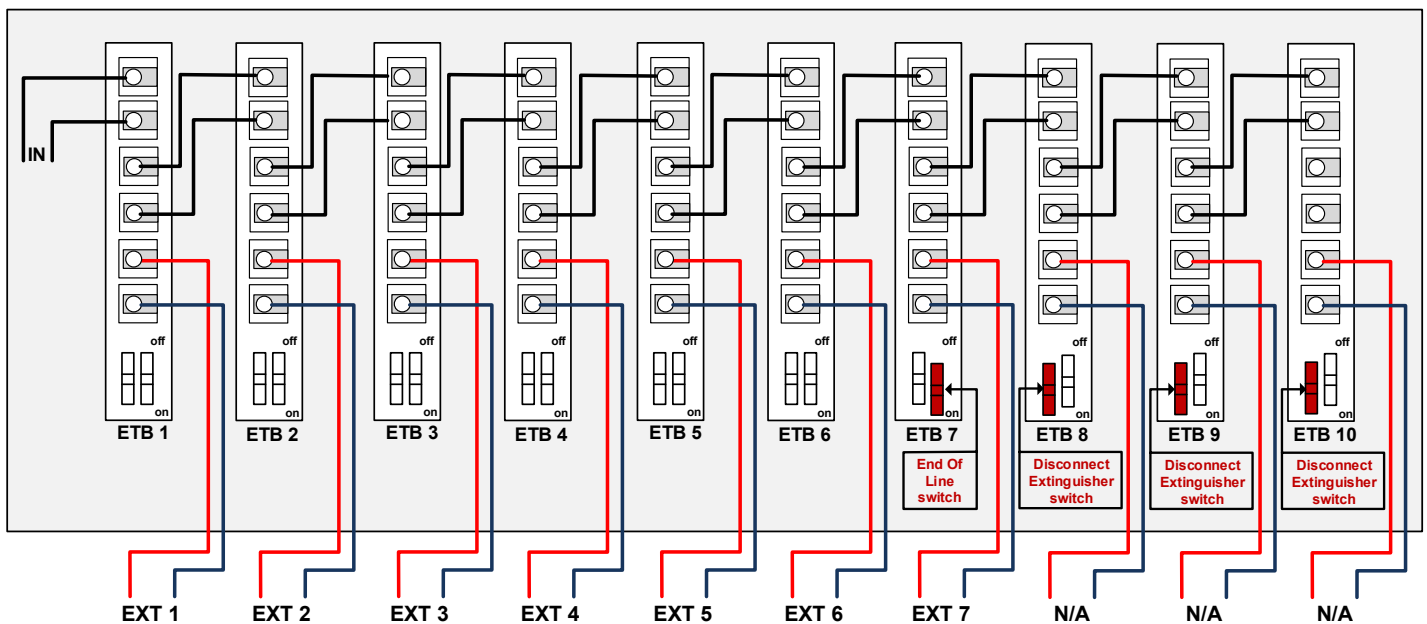

The ETB dip switch positions on a NETB 10 in use with 7 Stat-X extinguishers



21 THE NANO MAR SYSTEM USING A SOLENOID ACTIVATOR

In addition to a fire extinguishing output for electric igniters meant for aerosol fire extinguishing generators, the NANO control panel also has an extinguishing output suitable for a solenoid-controlled fire extinguishing system.

The extinguishant output is capable of supplying up to 1 Amp for the maximum duration to a solenoid. Solenoids must have a resistance of 25 to 200 ohms 18/28V DC, to ensure that the maximum current rating of the extinguishant output is not exceeded. The maximum cable impedance is 1.5Ω-5.0Ω depending on the coil impedance.

Calculate the voltage drop across the cable to ensure that sufficient voltage remains at the end of the control cable for the activation of the solenoid activator.

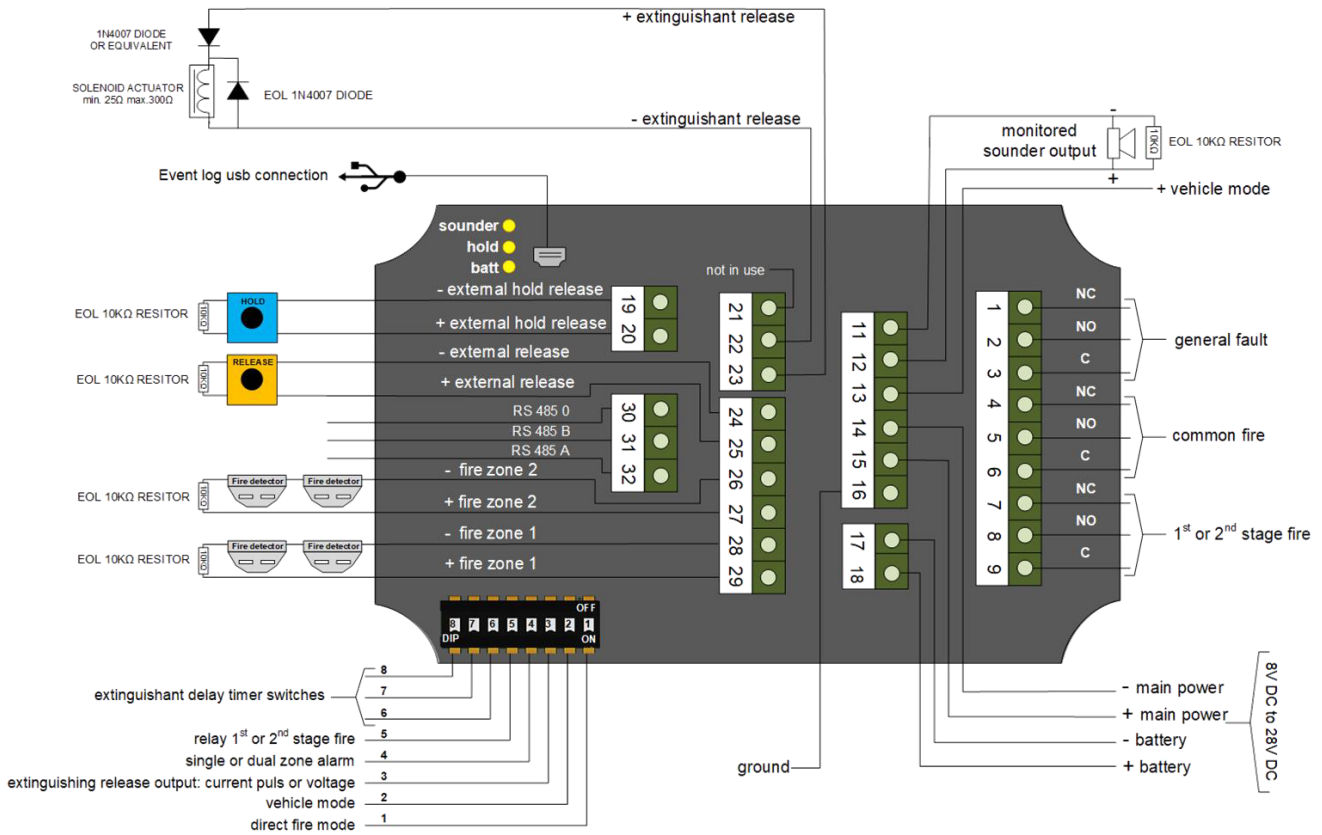

21.1 WIRING A SOLENOID ACTIVATION SYSTEM

The solenoid should be fitted with two diodes. One diode for the end of line monitoring. The other is a flyback diode. A fly back diode is a diode connected across the coil used to eliminate flyback, which is the sudden voltage spike seen across an inductive load when its supply current is suddenly reduced or interrupted. It is used in circuits with a possible inductive load.

IMPORTANT

Despite the presence of a button on the NANO control panel front for manual extinguishing activation only, we do recommend a service/maintenance key switch in the extinguishing output line to perform test and maintenance work without activating the extinguishing system.

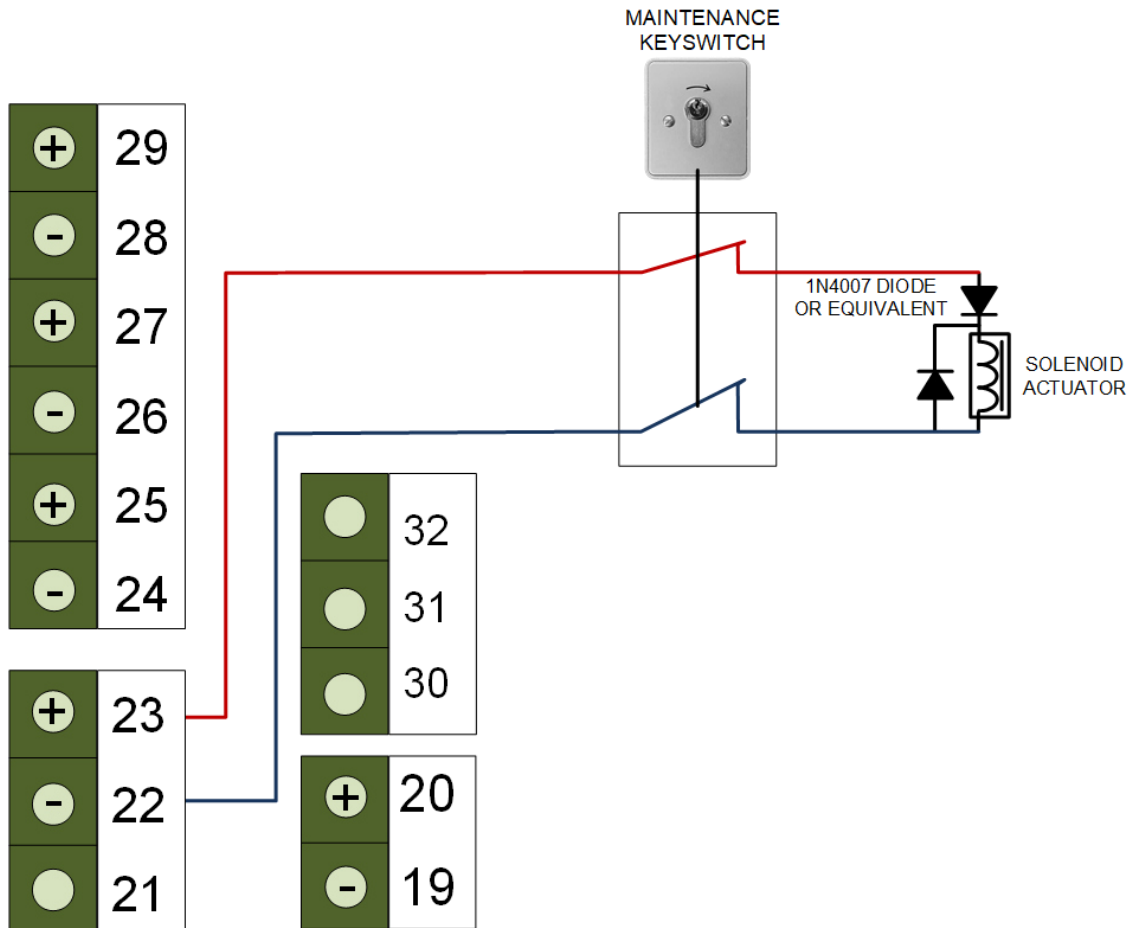

22 WIRING & CABLE SPECIFICATIONS:

- There is NO need for shielded cable
- Use a pair twisted cable, this strength the protection against electrical or magnetic field.
- Minimal solid copper core diameter, extinguisher line cable <50 meters length 1,0 mm² (AWG 18)
- Minimal solid copper core diameter, extinguisher line cable >50 meters length 1,5 mm² (AWG 16)
- Minimal solid copper core diameter, fire detection cables 0,5mm² (AWG 20)
- Maximum solid copper core diameter other cables 1,0mm² (AWG 18)
- Maximum conductor loop resistance, 1,5mm² cable is 24 Ω/km.
- Maximum cable length of the fire zone cables is 50 meters
- Maximum cable length of the cable from NANO control panel to NANO extinguishers terminal box is 30 meters
- The total cable length of all extinguishers together is max 125 meters in total



23 TECHNICAL SPECIFICATION

Environment

Ambient Temperature Range	-25 to +55 degrees Celsius
Dust and water rating	IP65
Compass safe distance	minimum 50 mm

Power related specification

Input voltage main and emergency battery	12/24 VDC +/- 30%
Maximum power usage	1 Watt quiescent 5 Watt in alarm
Maximum contact rate relays	30 VDC/1A
Voltage fire zone	15 Vdc
Limited alarm current fire detectors	60 mA
Sounder / beacon voltage main powered mode	12 – 22 VDC
Sounder / beacon alarm maximum current	150 mA

Connector and cable specification

Conductor cross section solid (Cross Sectional Area mm ²)	0.5 mm ² ... 1.5 mm ²
Conductor cross section flexible (Cross Sectional Area mm ²)	0.5 mm ² ... 1.5 mm ²
Conductor cross section AWG	20 ... 16
Stripping length	8 mm

Aerosol extinguisher output specification

Maximum Stat-X extinguisher count	10 connected on NANO extinguishers terminal box max 125 meters cable in total
Extinguisher release current	1,3A
Extinguisher release pulse length	35 ms

Solenoid extinguisher output specification

End of line component	2 x back - EMF diodes 1N4004 or equal
Maximum number solenoids	1
Maximum coil resistance	25 to 200 ohms
Maximum current	1 A
Voltage	24Vdc
Extinguisher release pulse length	8 seconds

Detection zone, hold and extinguishing release inputs

Normal state	> 8 kΩ < 12 kΩ
Alarm load	< 100 Ω >1.2 kΩ
Zone fault threshold 1	< 100 Ω
Zone fault threshold 2	> 1.2 kΩ < 8 kΩ
Zone fault threshold 3	> 12 kΩ
Alarm resistant	470 Ω
End of line resistant	10 kΩ



24 DEVICES RECOMMENDED AND SUPPORTED BY THE NANO SYSTEM

24.1 DETECTION DEVICE SUPPORT

The detector types below have been evaluated on the NANO CONTROL PANEL and are		
Part no	Type	Brand
ORB-OP-42001-MAR ¹	smoke detector	Apollo
ORB-OH-43001-MAR ¹	smoke/heat detector	Apollo
ORB-HT-41002-MAR ¹	heat 61°C detector	Apollo
ORB-HT-41004-MAR ¹	heat 73°C detector	Apollo
ORB-HT-41006-MAR ¹	heat 90°C detector	Apollo
ORB-MB-00001-MAR	standard detector base	Apollo

24.2 SOUNDER / BEACON DEVICE SUPPORT

Part no	Type	Brand
YL40/DL/C/25/WN/WR	sounder beacon	Clifford Snell
VTB-32EM-DB-RB/RL (VTB ²)	Sounder beacon	Cranford

Note: 1 Device input voltage 8 – 22 VDC

Note: 2 Device input voltage 18 – 22 VDC

Always check the specification of the devices before installing them on the NANO control panel.

25 ENCLOSURE SPECIFICATIONS NANO CONTROL PANEL

- outside enclosure : 120 x 80 x 58,5 mm w x h x d
- protection class : IP 65
- color of enclosure : black RAL 9005
- enclosure material : ABS suitable for outdoor use
- cable gland holes : 7 predrilled holes

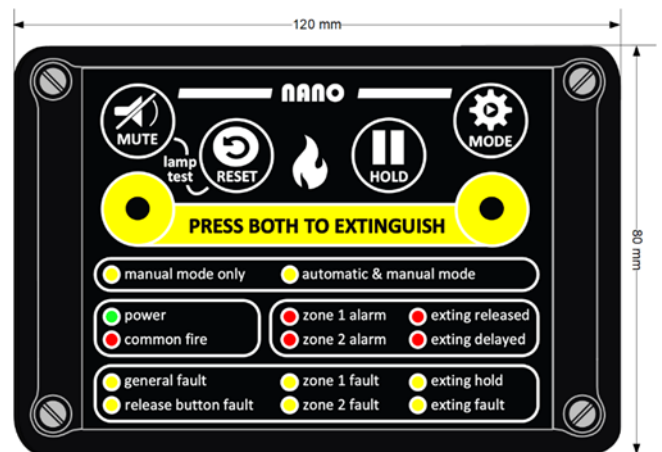
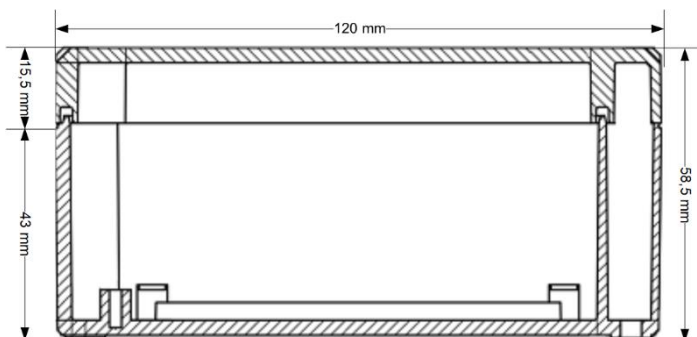

26 NANO MAR SYSTEM FIRE DETECTOR AND WIRING OPTIONS

There are three options for connecting fire detectors to the NANO control panel.

- Conventional Apollo Orbis MAR fire detectors
- Heat detectors
- Linear cable heat detection

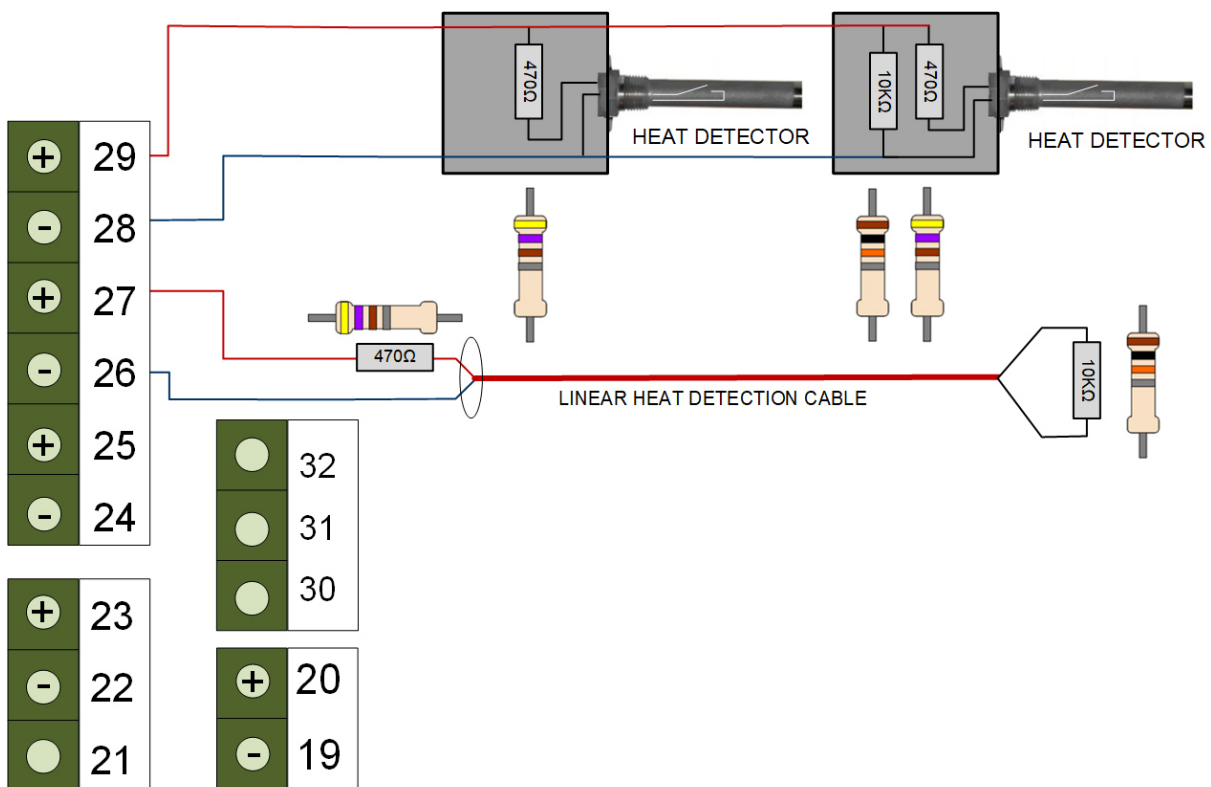
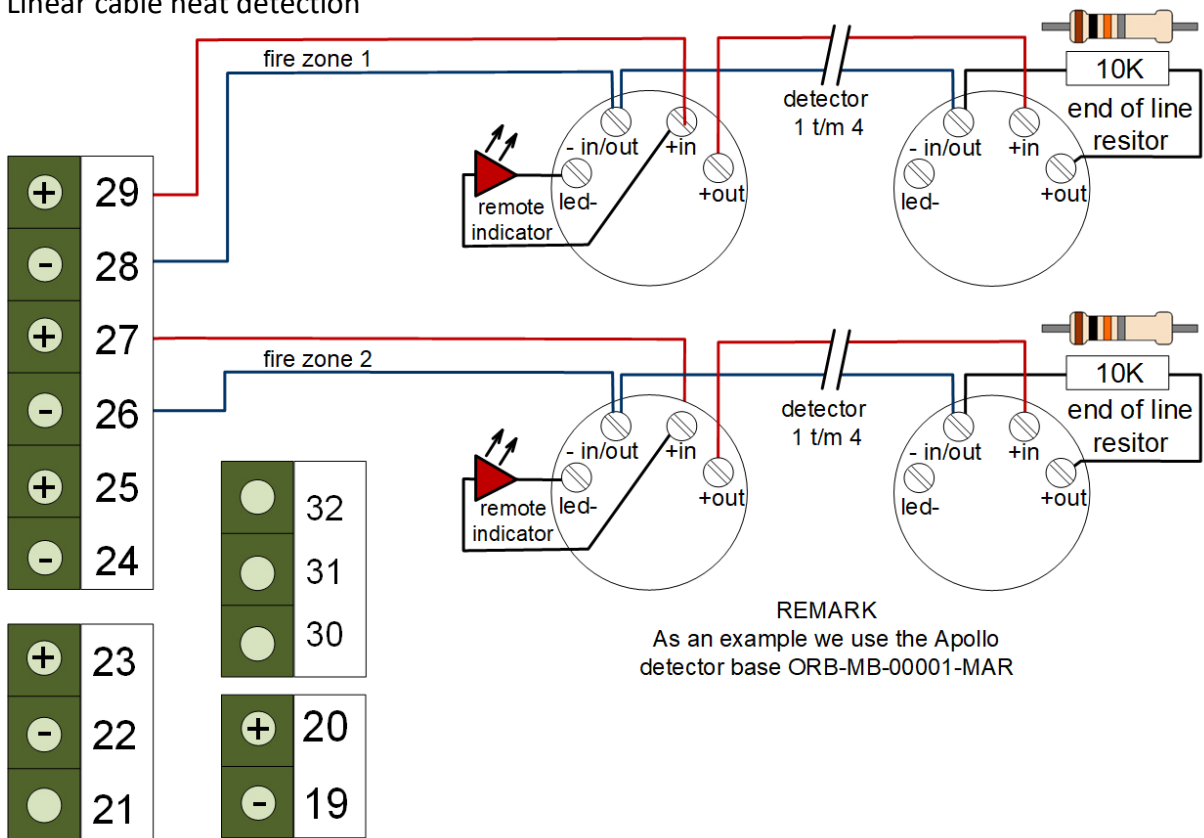

27 EXTERNAL EXTINGUISHERS RELEASE & HOLD WIRING OPTIONS

The NANO control panel has a separate input for external extinguishing release and external hold-off button.

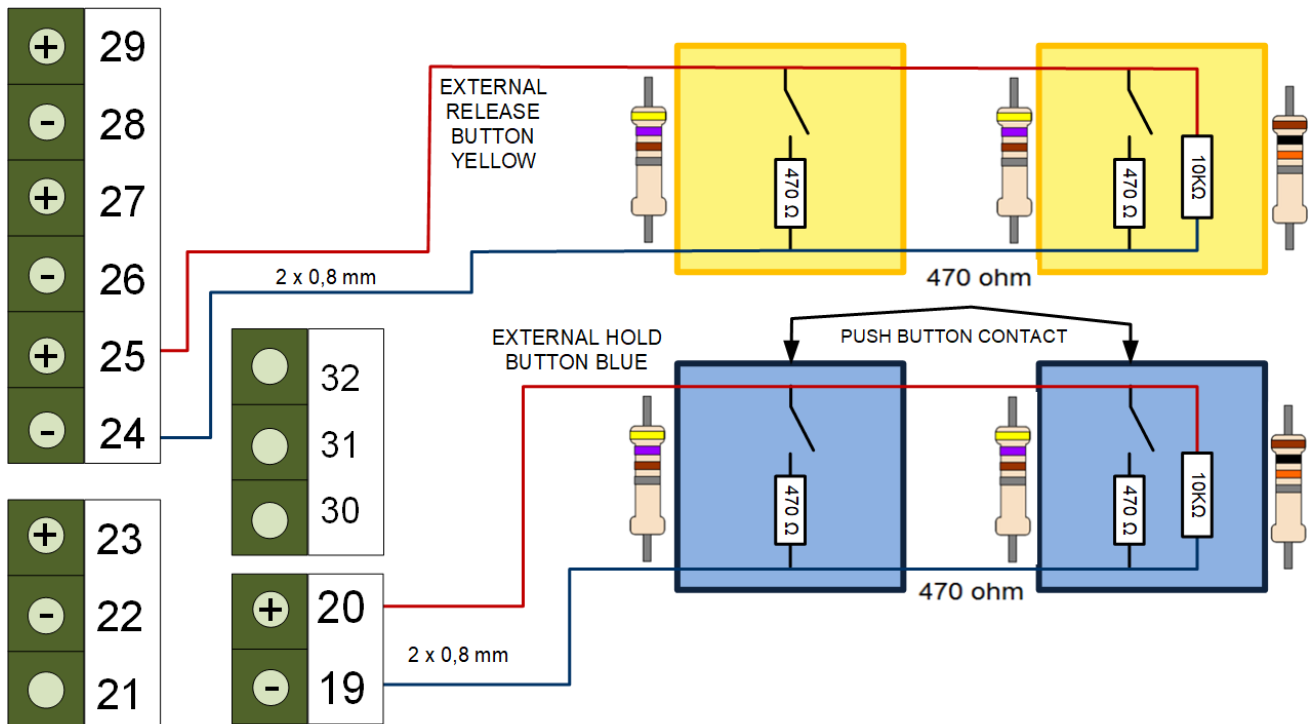

28 YL 40 WIRING OPTION SOUNDER & BEACON

By a single sounder beacon follow the connection diagram below. The recommended setting gives the best and deviating alarm signal compared to the usual evacuation alarm signal on vessels.

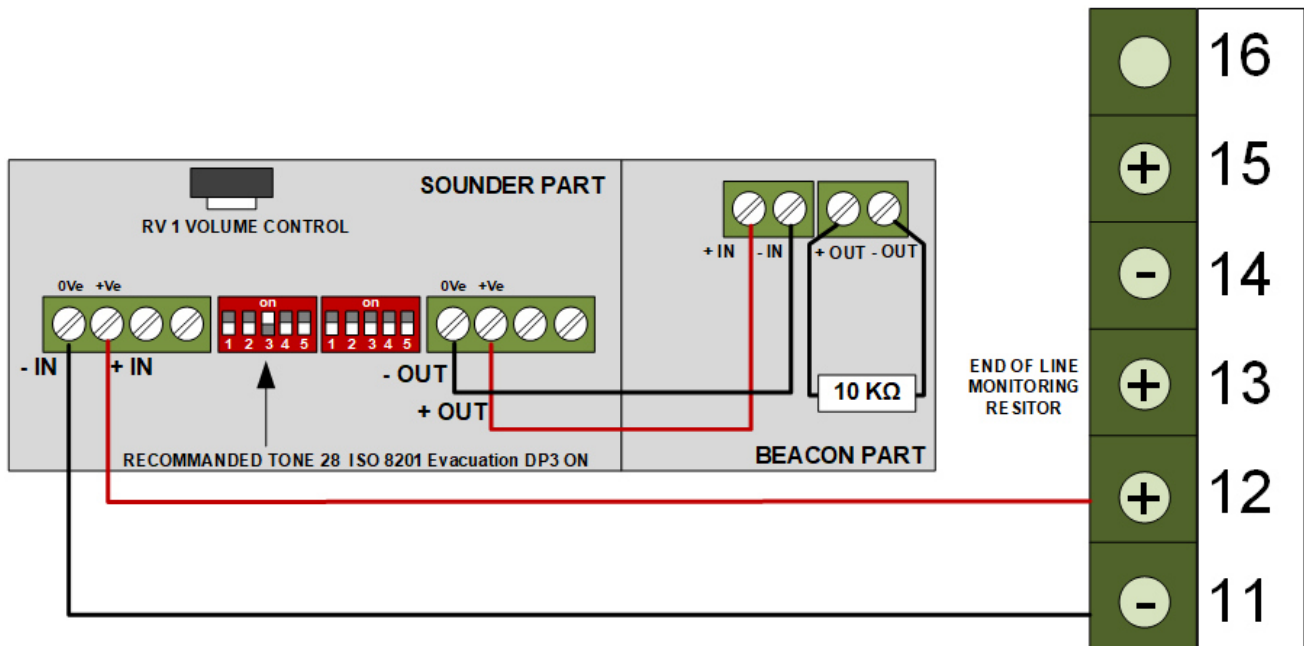

29 VTB-EM WIRING OPTION SOUNDER & BEACON

By a single sounder beacon follow the connection diagram below. The recommended setting gives the best and deviating alarm signal compared to the usual evacuation alarm signal on vessels.

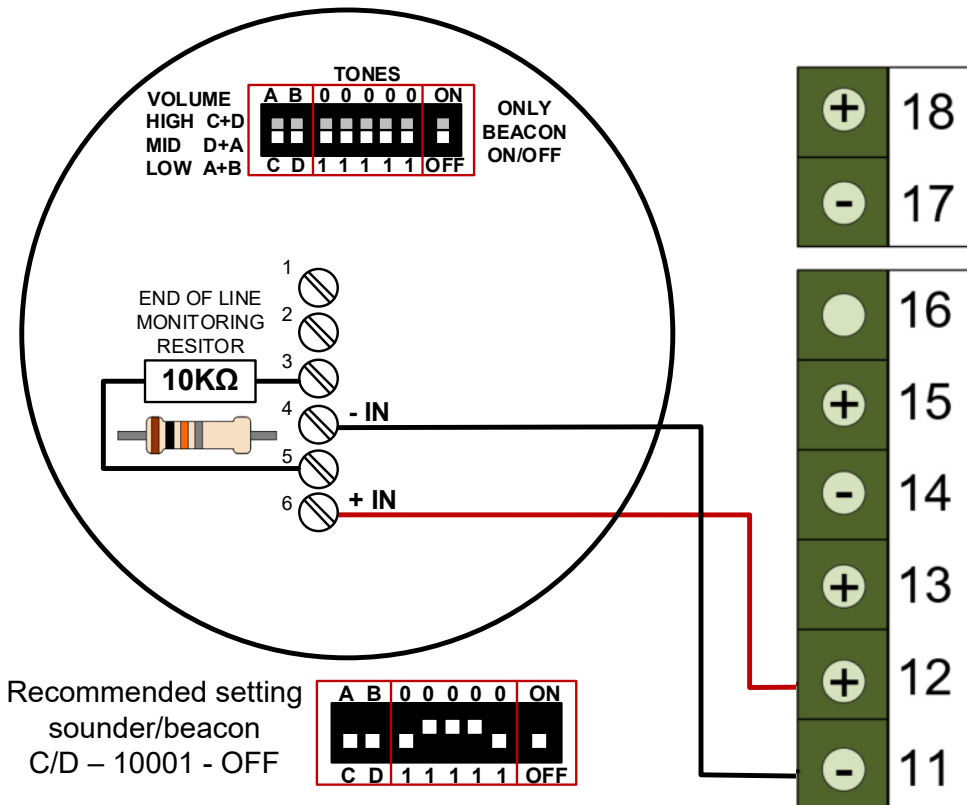

30 YL 40 WIRING OPTION EXTENDED SOUNDER & BEACONS

In some cases, the installation of a second signaling device is necessary. Usually this is caused by the lack of visibility of the optical alarm beacon in the protected area. In a noisy environ, the optical alarm signal is the leading warning element. By more than a single sounder beacon follow the connection diagram below. The recommended setting gives the best and deviating alarm signal compared to the usual evacuation alarm signal on vessels. At some sounders the end of line resistor is not necessary, because the resistance of the sounder input is sufficient to monitor on short circuit and/or wire break.

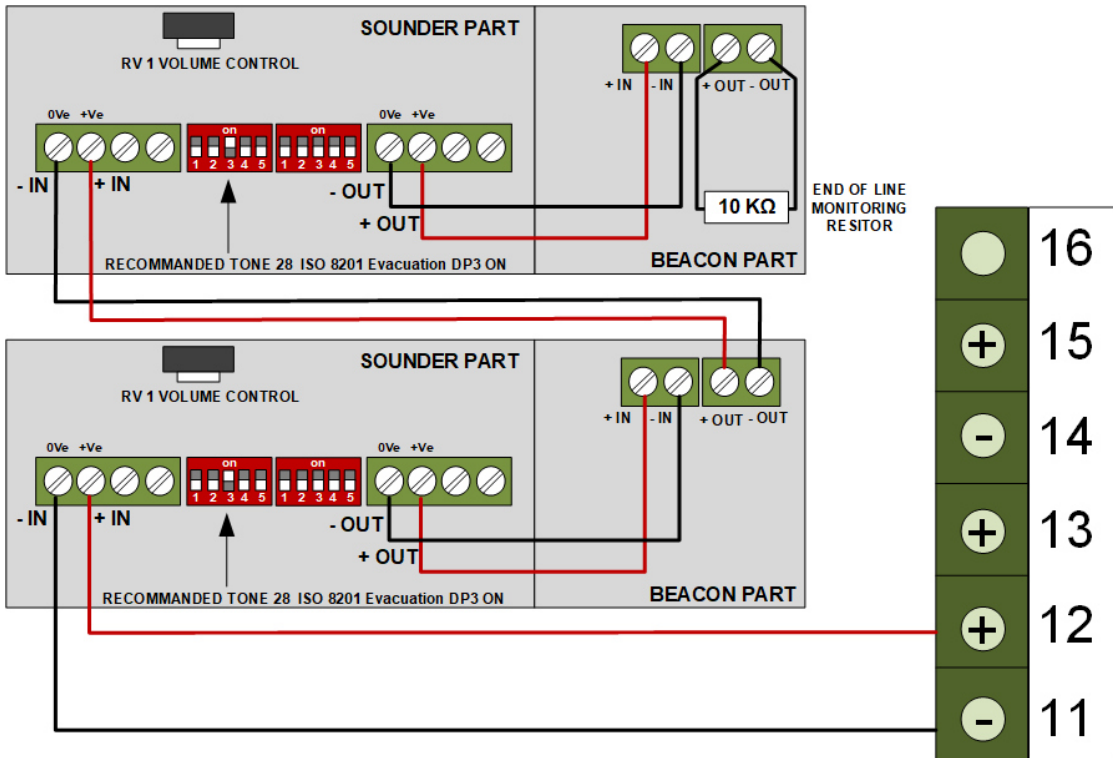

31 VTB-EM WIRING OPTION EXTENDED SOUNDER & BEACONS

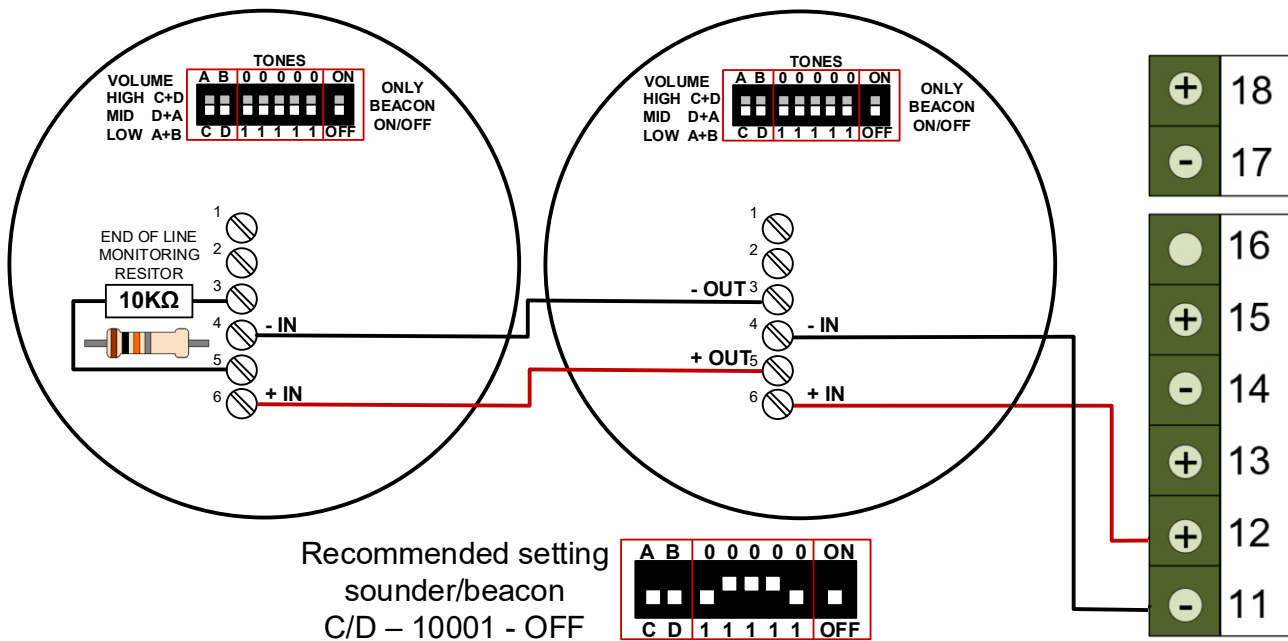

32 WARRANTY

K&G GROEP B.V. represents the NANO MAR SYSTEM and is free from material defects in materials and workmanship. Our warranty does not cover a NANO MAR SYSTEM which is damaged, misused, and/or used contrary to the supplied operating manuals or which has been repaired or altered by others. The liability of K&G GROEP B.V. is at all times limited to repair or, at K&G GROEP BV's discretion, replacement of the NANO MAR SYSTEM. K&G GROEP B.V. shall not under any circumstances be liable for any indirect, special, or consequential damages such as, but not limited to, damage or loss of property or equipment, cost of de-installation or reinstallation, cost of transport or storage, loss of profits or revenue, cost of capital, cost of purchased or replacement goods, or any claims by customers of the original purchaser or third parties or any other similar loss or damage, whether incurred directly or indirectly. Remedies set forth herein to the original purchaser and all others shall not exceed the price of the NANO MAR SYSTEM supplied. This warranty is exclusive and expressly in lieu of all other warranties, whether expressed or implied, including, without limitation, any warranties of merchantability or fitness for a particular purpose. The warranty may be void if the equipment is damaged by ESD. Daily use of the NANO MAR SYSTEM is described in the NANO Owners Manual

33 NOTES



The diagrams of operating principles of the NANO MAR fire-/extinguisher system, included in this manual, are intended to support this manual and are therefore not intended and suitable for technical implementation or realization. No part of this manual may be reproduced, stored in an automated database, or made public in any form or by any means either electronically, mechanically or by photocopying, recording, or in any other way, without prior written permission from K&G GROEP B.V. The policy of the K&G GROEP B.V. is one of continuous improvement and as such we reserve the right to amend product specifications at any time and without prior notice. Errors and omissions excepted.

Outdated or replaced computers and electronics are valuable sources for secondary raw materials, if recycled. Dealers of the NANO MAR SYSTEM must comply with local regulations for waste separation applicable in the country where the supplier is located. Questions concerning the information presented in this manual may be addressed to your dealer. For technical questions or support contact your dealer or further assistance.

